

CONTENTS

A. Machine body	1
B. Upper shaft and needle bar mechanism	3
C1. Feed mechanism	5
C2. Feed mechanism	7
C3. Feed mechanism	9
C4. Feed mechanism	11
D. Presser foot lifter mechanism	13
E. Thread wiper mechanism	13
F. Lower shaft mechanism	15
G. Lubrication	17
H. Threading mechanism	19
J. Bobbin winder mechanism	21
K. Thread trimmer mechanism	23
L. Thread nipper mechanism	27
M. Synchronizer	27
N1. Control box mechanism	29
N2. Control box mechanism	33
P. Power supply equipment mechanism	37
Q. Printed circuit board mechanism	39
R. Power table	39
S1. Foot switch pedal mechanism	41
S2. Foot switch pedal mechanism	43
Z. Accessories	45
DIFFERENT PARTS LIST	49

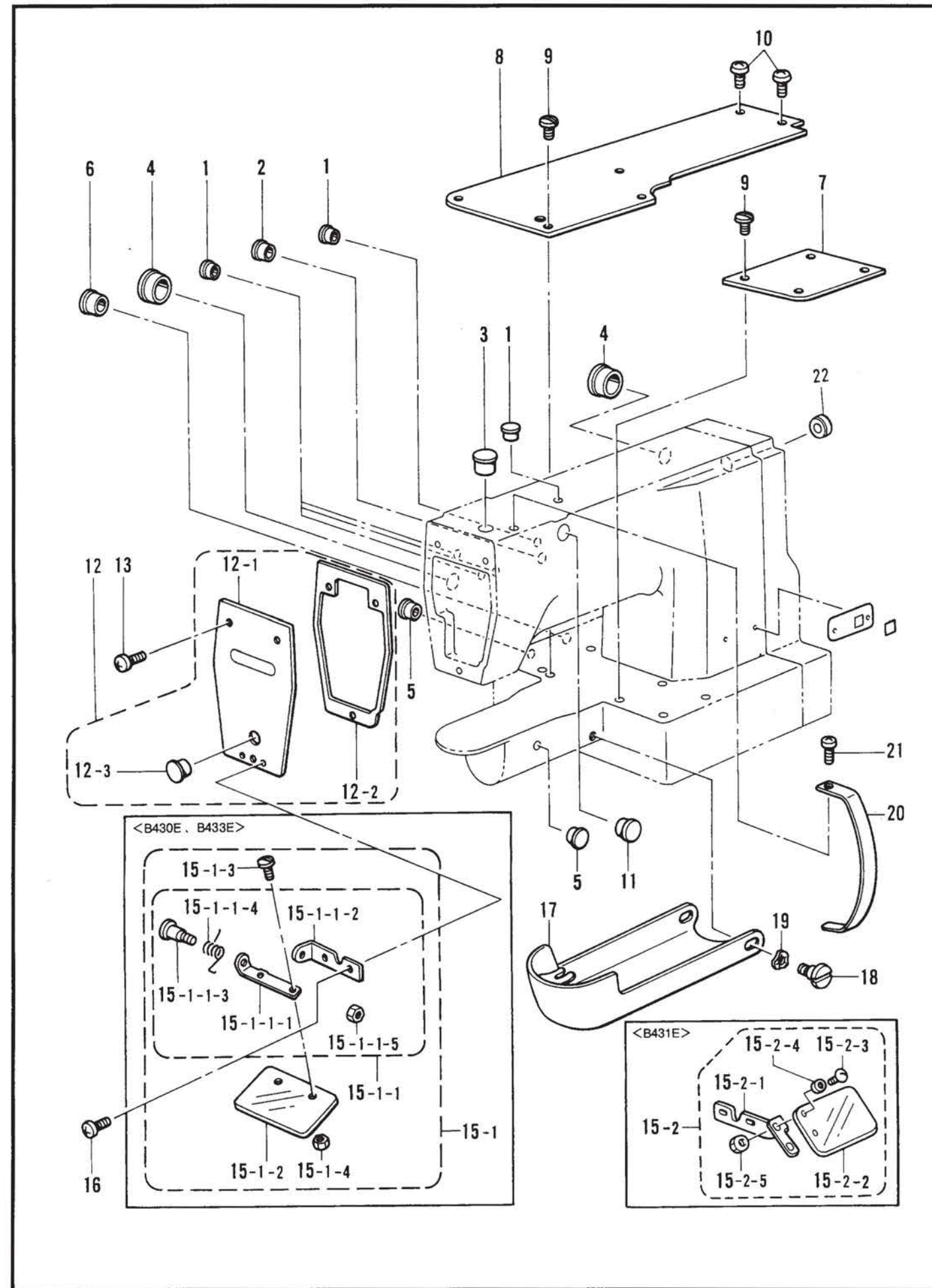

118-Z30-050

REF.NO.	CODE	Q'TY	ヒンメイ	NAME OF PARTS	RM
1	104450109	5	ゴムセン 8	RUBBER CAP, 8	
2	104821009	1	ゴムセン 10.5	RUBBER CAP, 10.5	
3	117934009	1	ゴムセン 13.5	RUBBER CAP, 13.5	
4	140392009	2	オイルフタ	OIL CAP	
5	104450109	2	ゴムセン 8	RUBBER CAP, 8	
6	104449009	1	ゴムセン 15.5	RUBBER CAP, 15.5	
7	S37915009	1	ベッドカバーR	BED COVER (R)	
8	S37916009	1	ベッドカバーL	BED COVER (L)	
9	106629002	8	シメネジ4.37	SCREW, SM4.37	
10	062681012	2	ナベコ437-40X10	SCREW, PAN SM4.37-40X10	
11	S23337009	1	ゴムセン 18.5	RUBBER CAP, 18.5	
12	S37917009	1	メンイタクミ	FACE PLATE ASSY	
12-1	S37918009	1	メンイタ	FACE PLATE	
12-2	S37919000	1	メンイタパツキン	PACKING	
12-3	117934009	1	ゴムセン 13.5	RUBBER CAP, 13.5	
13	060670812	3	バインド357-40X8	SCREW, BIND M3.57-40X8	
16	062670512	2	ナベコ357-40X5	SCREW, PAN SM3.57-40X5	
17	152842009	1	オオカマカバークミ	LARGE SHUTTLE HOOK COVER ASSY	
18	145480101	2	ダンネジ6.35	SHOULDER SCREW, SM6.35	
19	109239002	2	ナミバネザガネ	WASHER, WAVE SPRING	
20	S37920009	1	テンビンカバー	THREAD TAKE-UP COVER	
21	062680612	1	ナベコ4.37-40X6	SCREW, PAN SM4.37-40X6	
22	S20164009	1	ゴムセン13	RUBBER CAP, 13	
<B430E,B433E>					
15-1	S36684001	1	アイガードクミ	EYE GUARD ASSY	
15-1-1	S36691001	1	アイガードトリツケイタクミ	EYE GUARD SET PLATE ASSY	
15-1-1-1	S34844001	1	アイガードトリツケイタ	EYE GUARD SET PLATE	
15-1-1-2	S34845001	1	アイガードドダイ	EYE GUARD BASE	
15-1-1-3	S36071001	1	アイガードシテンネジ	EYE GUARD SCREW	
15-1-1-4	S36070001	1	アイガードモドシバネ	EYE GUARD SPRING	
15-1-1-5	106129002	1	ナツト3.57	NUT, SM3.57	
15-1-2	153098000	1	アイガード	EYE GUARD	
15-1-3	100257010	2	シメネジ3.57	SCREW, M3.57	
15-1-4	106129002	2	ナツト3.57	NUT, SM3.57	
<B431E>					
15-2	S36685101	1	アイガードクミ	EYE GUARD ASSY	
15-2-1	S36686101	1	アイガードササエイタ	EYE GUARD SUPPORT PLATE	
15-2-2	143966001	1	アイガード	EYE GUARD	
15-2-3	062660712	2	ナベコ318-40X7	CREW, PAN SM3.18-40X7	
15-2-4	025660132	2	ヒラザガネシヨウ 3.18	WASHER, PLAIN S 3.18	
15-2-5	021660102	2	ナツト1シユ3.18	NUT, 1 M3.18	

From the library of: Diamond Needle Corp

118-Z30-050

B. 上軸・針棒関係 / Upper shaft and needle bar mechanism / Obere Welle und Nadelstangenvorrichtung / Mécanisme de arbre supérieur et barra à aiguille / Mecanismo del eje superior y la barra de aguaia

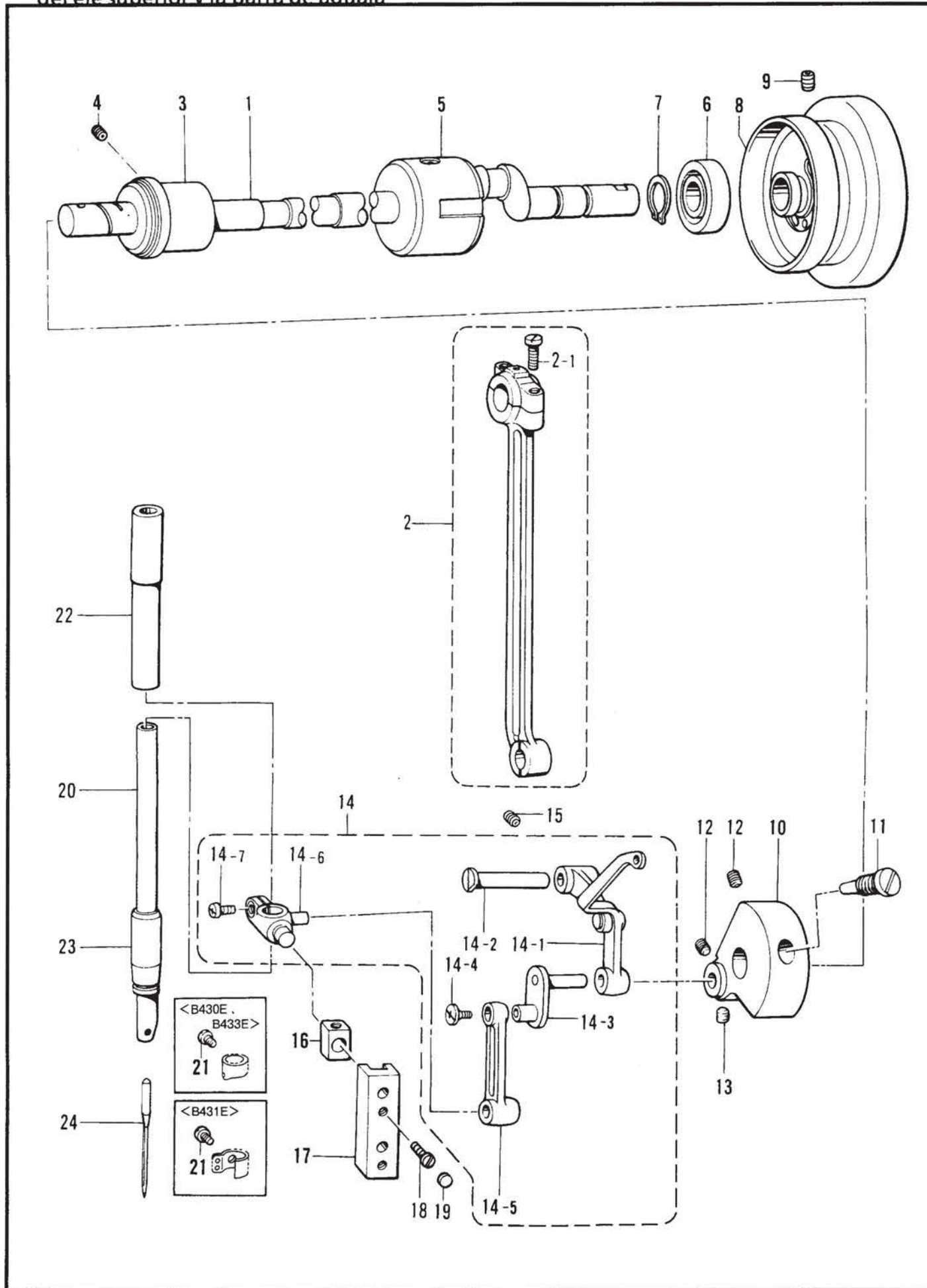

118-Z30-123

B. 上軸・針棒関係 / Upper shaft and needle bar mechanism / Obere Welle und Nadelstangenvorrichtung / Mécanisme de arbre supérieur et barra à aiguille / Mecanismo del eje superior y la barra de aguaia

REF.NO.	CODE	Q'TY	ヒンメイ	NAME OF PARTS	RM
1	S37923001	1	ウワジク	UPPER SHAFT	
2	153040001	1	クランクロッドクミ	CRANK ROD ASSY	
2-1	144712001	2	シメネジ4.76	SCREW 4.76	
3	S10038001	1	ウワジクメタルF	UPPER SHAFT BUSH (F)	
4	014780622	1	アナトメネジ6.35クボミ	SET SCREW, SOCKET (CP) SM6.35	
5	140726000	1	ウワジクメタルM	UPPER SHAFT BUSH (M)	
6	072630260	1	ベアリング6302VV	BALL BEARING 6302VV	
7	048150142	1	トメワジクヨウC15	RETAINING RING, C15	
8	S38035009	1	プーリクミ	PULLEY ASSY	
9	014760622	2	アナトメネジ5.95	SET SCREW, SOCKET (CP) SM5.95	
10	152231000	1	シリアイクランク	COUNTER WEIGHT	
11	100250001	1	シメネジ7.14	SCREW, SM7.14	
12	014770622	2	アナトメネジ6.35クボミ	SET SCREW, SOCKET (CP) SM6.35	
13	101706001	1	トメネジ6.35	SET SCREW, SM6.35	
14	S37925001	1	ハリボウレンカクミ	THREAD TAKE-UP LEVER ASSY	
14-1	153330101	1	テンピンクミ	THREAD TAKE-UP ASSY	
14-2	152236001	1	テンピンササエジク	THREAD TAKE-UP SUPPORT STUD	
14-3	152237001	1	ハリボウクランク	NEEDLE BAR CRANK	
14-4	132051001	1	+サラネジ3.57L	SCREW, FLAT SM3.57L	
14-5	152238001	1	ハリボウレンカン	THREAD TAKE-UP LEVER	
14-6	S37926001	1	ハリボウダキ	NEEDLE BAR CLAMP	
14-7	062680812	1	ナベコ437-40X8	SCREW, PAN SM4.37-40X8	
15	014780622	1	アナトメネジ6.35クボミ	SET SCREW, SOCKET (CP) SM6.35	
16	102630001	1	ハリボウアンナイカクコマ	NEEDLE BAR GUIDE SLIDE BLOCK	
17	S37927000	1	ハリボウアンナイ	NEEDLE BAR GUIDE	
18	100242003	2	シメネジ3.57	SCREW, SM3.57	
19	155578000	2	ゴムセン	OIL CAP	
20	152240101	1	ハリボウA	NEEDLE BAR (A)	
21	144458001	1	アタマツキトメネジ3.57	SET SCREW, SM3.57	
22	152242001	1	ハリボウメタルU	NEEDLE BAR BUSH (U)	
23	152243001	1	ハリボウメタルD	NEEDLE BAR BUSH (D)	
24	※	1	ミシンハリ	NEEDLE	

From the library of: Diamond Needle Corp

118-Z30-123

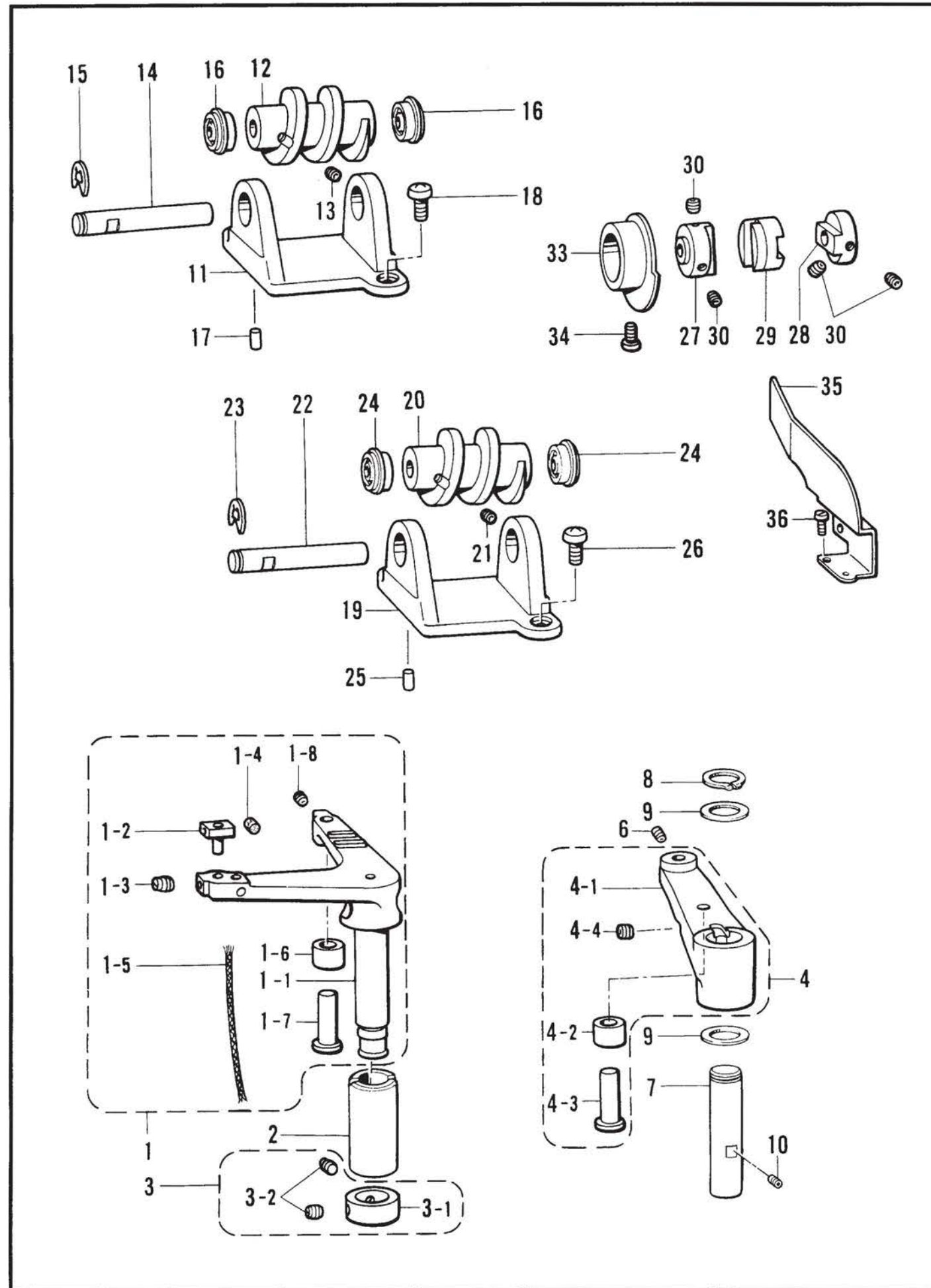

118-Z30-202

REF.NO.	CODE	Q'TY	ヒンメイ	NAME OF PARTS	RM
1	S37930001	1	Xオクリレバークミ	X FEED LEVER ASSY	
1-1	S37931001	1	Xオクリレバー	X FEED LEVER	
1-2	153041001	1	ヨコオクリカクゴマクミ	TACK LENGTH SLIDE BLOCK ASSY	
1-3	151602002	1	トメネジ4.37	SET SCREW, M4.37	
1-4	153924001	1	フェルト	FELT	
1-5	108802001	1	クミヒモ4X4	WICK 4X4 (L = 250)	
1-6	S37932001	1	オクリカムコロ	FEED CAM ROLLER	
1-7	S37933001	1	コロジク	ROLLER SHAFT	
1-8	014760622	1	アナトメネジ5.95	SET SCREW, SOCKET (CP) SM5.95	
2	S37934001	1	Xオクリレバークミ	X FEED LEVER BUSH	
3	183493001	1	オクリジクセットカラー	FEED SHAFT SET COLLAR ASSY	
3-1	S09212001	1	セットカラー	SET SCREW COLLAR	
3-2	101706001	2	トメネジ6.35	SET SCREW, SM6.35	
4	S37935001	1	Yオクリレバークミ	Y FEED LEVER ASSY	
4-1	S37936001	1	Yオクリレバー	Y FEED LEVER	
4-2	S37932001	1	オクリカムコロ	FEED CAM ROLLER	
4-3	S37933001	1	コロジク	ROLLER SHAFT	
4-4	014760622	1	アナトメネジ5.95	SET SCREW, SOCKET (CP) SM5.95	
5	152759001	1	タテオクリジク	TACK WIDTH FEED SHAFT	
6	014760622	1	アナトメネジ5.95	SET SCREW, SOCKET (CP) SM5.95	
7	152760001	1	タテオクリレバークミ	TACK WIDTH LEVER ASSY	
8	048180142	1	トメワジクヨウC18	RETAINING RING, C18	
9	152756001	2	スラストザガネ18	THRUST WASHER 18	
10	014760622	1	アナトメネジ5.95	SET SCREW, SOCKET (CP) SM5.95	
11	S37937001	1	オクリカムブラケット	FEED CAM BRACKET	
12	S37938001	1	オクリカムX	FEED CAM X	
13	014760622	2	アナトメネジ5.95	SET SCREW, SOCKET (CP) SM5.95	
14	S37939001	1	カムジク	CAM SHAFT	
15	048060342	1	トメワE6	RETAINING RING, E6	
16	070688850	2	タマジクウケ688ZZNR	BALL BEARING 688ZZNR	
17	S37940001	2	イチギメピン	LOCATOR PIN	
18	062681012	2	ナベコ437-40X10	SCREW, PAN SM4.37-40X10	
19	S37937001	1	オクリカムブラケット	FEED CAM BRACKET	
20	S37941001	1	オクリカムY	FEED CAM Y	
21	014760622	2	アナトメネジ5.95	SET SCREW, SOCKET (CP) SM5.95	
22	S37939001	1	カムジク	CAM SHAFT	
23	048060342	1	トメワE6	RETAINING RING, E6	
24	070688850	2	タマジクウケ688ZZNR	BALL BEARING 688ZZNR	
25	S37940001	2	イチギメピン	LOCATOR PIN	
26	062681012	2	ナベコ437-40X10	SCREW, PAN SM4.37-40X10	
27	S37942000	2	カツプリングハブ8	COUPLING HUB 8	
28	S37943000	2	カツプリングハブ6.35	COUPLING HUB 6.35	
29	S37944000	2	カツプリングスペーサ	COUPLING SPACER	
30	014760622	8	アナトメネジ5.95	SET SCREW, SOCKET (CP) SM5.95	
33	S37946001	2	オクリゲンテンドグ	FEED HOME POSITION DOG	
34	062300512	2	ナベコ3X5	SCREW, PAN M3X5	
35	S37947001	2	ゲンテンセンサートリツケイタ	HOME POSITION SENSOR SET PLATE	
36	062680612	2	ナベコ4.37-40X6	SCREW, PAN SM4.37-40X6	

From the library of: Diamond Needle Corp

118-Z30-202

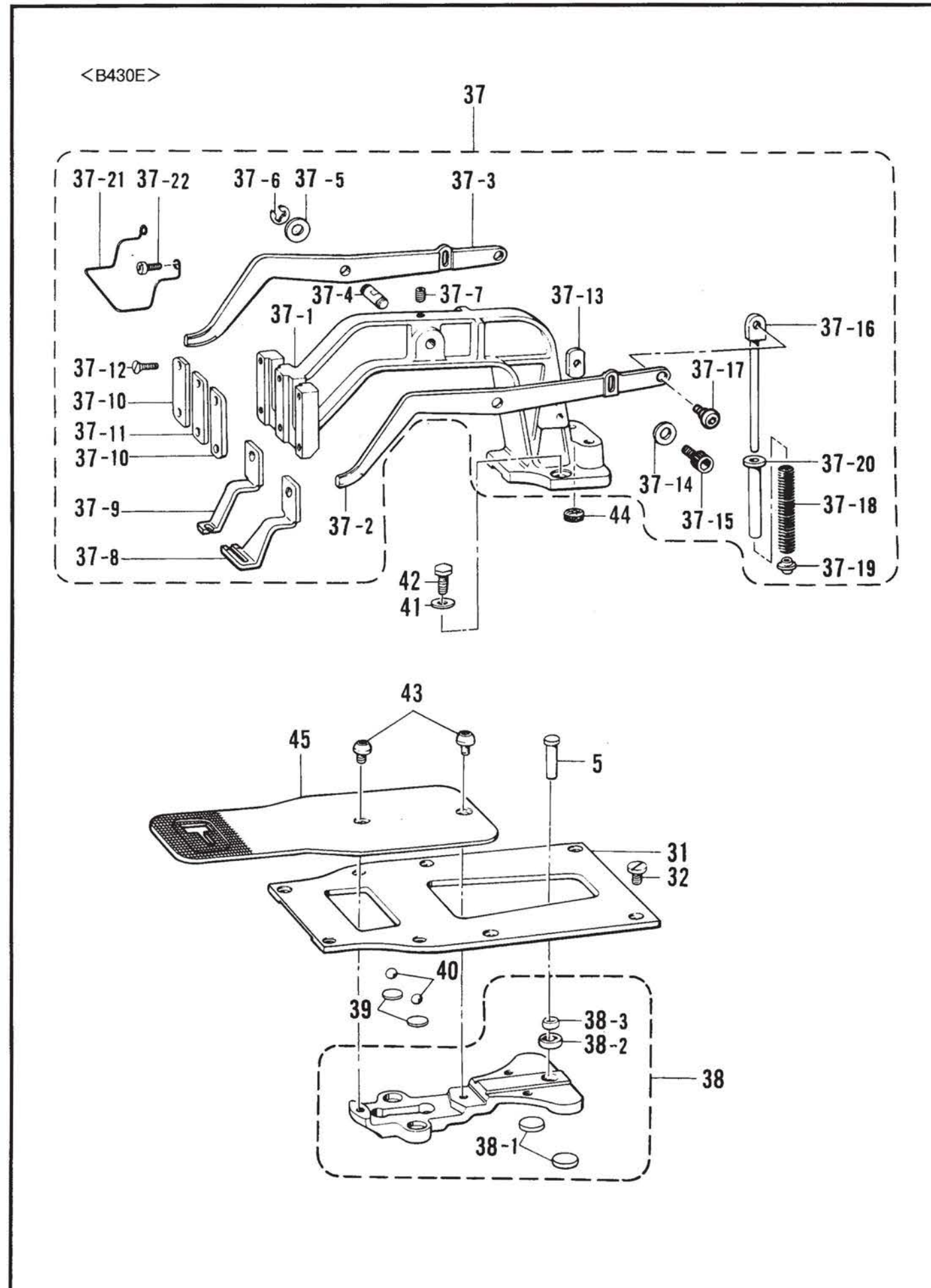

118-Z30-202

REF.NO.	CODE	Q'TY	ヒンメイ	NAME OF PARTS	RM
<B430E>					
31	S37945051	1	オクリダイヤモンド	FEED BAR GUIDE PLATE	
32	145318001	8	シメネジ4.37	SCREW, SM4.37	
37	※	1	オサエウデクミ	PRESSER ARM ASSY	
37-1	152768009	1	オサエウデ	PRESSER ARM	
37-2	S37949001	1	オサエウデレバーR	PRESSER ARM LEVER (R)	
37-3	S37950001	1	オサエウデレバーL	PRESSER ARM LEVER (L)	
37-4	S34839001	1	オサエウデレバーク	PRESSER ARM LEVER SHAFT	
37-5	116629001	2	ザガネ	WASHER	
37-6	048050342	2	トメワE5	RETAINING RING, E5	
37-7	014760622	1	アナトメネジ5.95	SET SCREW, SOCKET (CP) SM5.95	
37-8	※	1	オサエアシR	PRESSER FOOT (R)	
37-9	※	1	オサエアシL	PRESSER FOOT (L)	
37-10	152783001	2	オサエアシオサエイタA	PRESSER FOOT GUIDE PLATE (A)	
37-11	152784001	1	オサエアシオサエイタB	PRESSER FOOT GUIDE PLATE (B)	
37-12	107038003	6	サラネジ3.57	SCREW, FLAT SM3.57	
37-13	S37951001	2	オサエウデレバーイタ	PRESSER ARM LEVER PLATE	
37-14	146354001	2	ザガネ	WASHER, PLAIN 5	
37-15	018500822	2	アナボルト5X8	BOLT, SOCKET M5X8	
37-16	153570001	2	オサエバネアンナイロッド	SPRING GUIDE ROD	
37-17	145478101	2	ダンネジ4.76	SHOULDER SCREW, SM4.76	
37-18	※	2	オサエバネ	SPRING, EXTENSION	
37-19	152788000	2	オサエバネカンザ	SPRING COLLAR	
37-20	153567000	2	オサエバネカラー	SPRING COLLAR	
37-21	156495001	1	フィンガーガード	FINGER GUARD	
37-22	062671012	2	ナベコ357-40X10	SCREW, PAN M3.57-40X10	
38	152769001	1	オクリダイクミ	FEED BRACKET ASSY	
38-1	152771000	2	オクリダイカンザ	WASHER	
38-2	152773000	1	キユウメンブツシユメタル	BUSH	
38-3	141331001	1	キユウメンブシユ	BUSH	
39	152772001	2	カンザ	WASHER	
40	071047650	2	コウキユウ3/16	BEARING BALL 3/16	
41	025060232	2	ヒラザガネチユウ6	WASHER, PLAIN M 6	
42	017761412	2	ボルト5.95X14	BOLT, M5.95X14	
43	153057002	2	オクリイタシメネジ	SCREW, SOCKET SM4.37	
44	153035000	1	オサエウデフェルト	PRESSER ARM FELT	
45	※	1	オクリイタ	FEED PLATE	

From the library of: Diamond Needle Corp

118-Z30-202

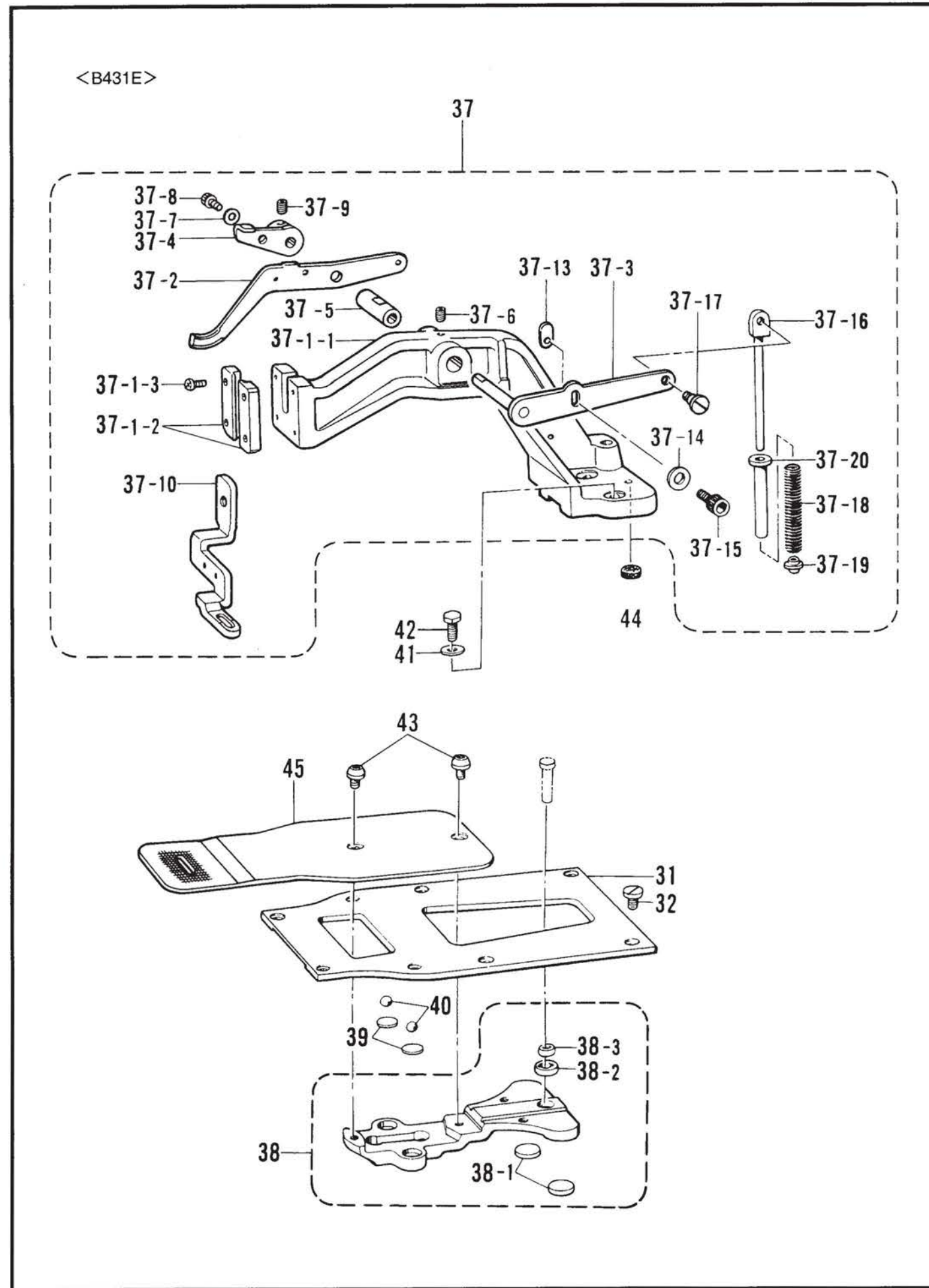

118-Z30-202

REF.NO.	CODE	Q'TY	ヒンメイ	NAME OF PARTS	RM
<B431E>					
31	537945051	1	オクリダイヤモンド	FEED BAR GUIDE PLATE	
32	145318001	8	シメネジ4.37	SCREW, SM4.37	
37	※	1	オサエウデクミ 431	PRESSER ARM ASSY 431	
37-1	159826009	1	オサエウデクミ	PRESSER ARM ASSY	
37-1-1	159825009	1	オサエウデ431	PRESSER ARM 431	
37-1-2	159827001	2	オサエアシオサエイタB	PRESSER FOOT GUIDE PLATE (B)	
37-1-3	062671212	4	ナベコ357-40X12	SCREW, PAN M3.57-40X12	
37-2	154413001	1	オサエウデレバーA	PRESSER ARM LEVER (A)	
37-3	541230001	1	オサエウデレバーB	PRESSER ARM LEVER (B)	
37-4	154415001	1	オサエウデレバーC	PRESSER ARM LEVER (C)	
37-5	153944001	1	レバーシフトメタル	LEVER SHAFT BUSH	
37-6	014760622	1	アタメネジ5.95	SET SCREW, SOCKET SM5.95	
37-7	140407002	1	ザガネ	WASHER	
37-8	018500822	1	アナボルト5X8	BOLT, SOCKET M5X8	
37-9	014770622	2	アタメネジ6.35クボミ	SET SCREW, SOCKET (CP) SM6.35	
37-10	※	1	オサエアシ431	PRESSER FOOT 431	
37-13	537951001	1	オサエウデレバーイタ	PRESSER ARM LEVER PLATE	
37-14	140407002	1	ザガネ	WASHER	
37-15	018500822	1	アナボルト5X8	BOLT, SOCKET M5X8	
37-16	159828001	1	オサエバネアンナイロッドB	GUIDE ROD (B)	
37-17	145478101	1	ダンネジ4.76	SHOULDER SCREW, SM4.76	
37-18	154418001	1	オサエバネ431	SPRING 431	
37-19	152788000	1	オサエバネカンザ	SPRING COLLAR	
37-20	153567000	1	オサエバネカラー	SPRING COLLAR	
38	152769001	1	オクリダイクミ	FEED BRACKET ASSY	
38-1	152771000	2	オクリダイカンザ	WASHER	
38-2	152773000	1	キユウメンブツシユメタル	BUSH	
38-3	141331001	1	キユウメンブシユ	BUSH	
39	152772001	2	カンザ	WASHER	
40	071047650	2	コウキユウ3/16	BEARING BALL 3/16	
41	025060232	2	ヒラザガネチユウ6	WASHER, PLAIN M 6	
42	017761412	2	ボルト5.95X14	BOLT, M5.95X14	
43	153057002	2	オクリイタシメネジ	SCREW, SOCKET SM4.37	
44	153035000	1	オサエウデフェルト	PRESSER ARM FELT	
45	※	1	オクリイタ 431	FEED PLATE 431	

From the library of: Diamond Needle Corp

118-Z30-202

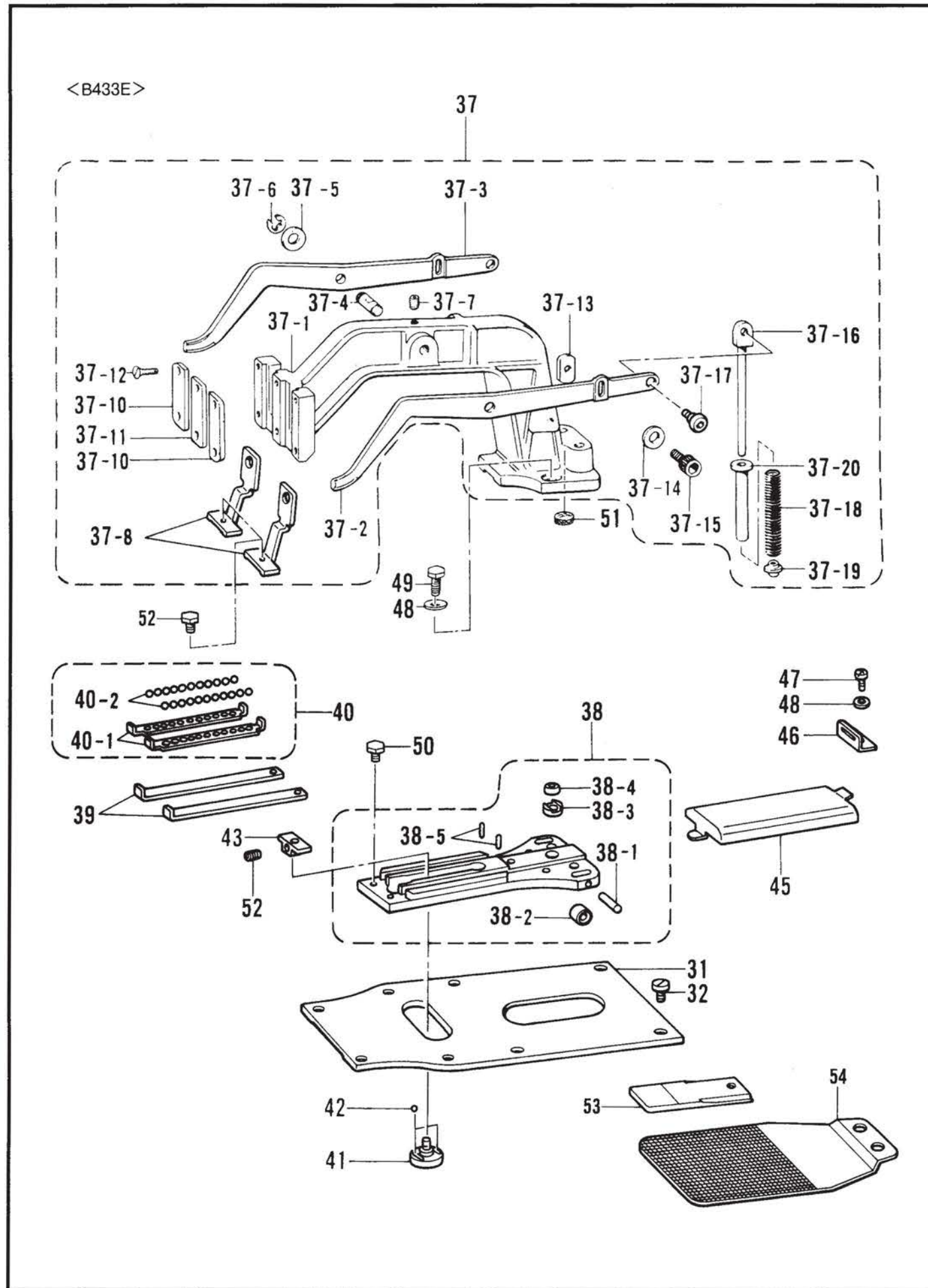

118-Z30-202

REF.NO.	CODE	Q'TY	ヒンメイ	NAME OF PARTS	RM
<B433E>					
31	S41236001	1	オクリダイアンナイイタ 433	FEED BAR GUIDE PLATE	
32	145318001	8	シメネジ4.37	SCREW, SM4.37	
37	※	1	オサエウデクミ A	PRESSER ARM ASSY (A)	
37-1	152768009	1	オサエウデ	PRESSER ARM	
37-2	S37949001	1	オサエウデレバー R	PRESSER ARM LEVER (R)	
37-3	S37950001	1	オサエウデレバー L	PRESSER ARM LEVER (L)	
37-4	S34839001	1	オサエウデレバージク	PRESSER ARM LEVER SHAFT	
37-5	116629001	2	ザガネ	WASHER	
37-6	048050342	2	トメワE5	RETAINING RING, E5	
37-7	014760622	1	アナトメネジ5.95	SET SCREW, SOCKET (CP) SM5.95	
37-8	156006001	2	オサエアシ	PRESSER FOOT	
37-10	152783001	2	オサエアシオサエイタ A	PRESSER FOOT GUIDE PLATE (A)	
37-11	152784001	1	オサエアシオサエイタ B	PRESSER FOOT GUIDE PLATE (B)	
37-12	107038003	6	サラネジ3.57	SCREW, FLAT SM3.57	
37-13	S37951001	2	オサエウデレバーイタ	PRESSER ARM LEVER PLATE	
37-14	146354001	2	ザガネ	WASHER, PLAIN 5	
37-15	018500822	2	アナボルト5X8	BOLT, SOCKET M5X8	
37-16	153570001	2	オサエバネアンナイロツド	SPRING GUIDE ROD	
37-17	145478101	2	ダンネジ4.76	SHOULDER SCREW, SM4.76	
37-18	※	2	オサエバネ	SPRING, EXTENSION	
37-19	152788000	2	オサエバネカンザ	SPRING COLLAR	
37-20	153567000	2	オサエバネカラー	SPRING COLLAR	
38	S41243001	1	オクリダイクミ 433	FEED BRACKET ASSY 433	
38-1	153377001	2	コロ A 3X17.8	ROLLER A 3X17.8	
38-2	153378001	2	オクリダイコロ	FEED GUIDE ROLLER	
38-3	152773000	1	キユウメンブッシュメタル	BUSH	
38-4	141331001	1	キユウメンブッシュ	BUSH	
38-5	148133001	2	コロ A	ROLLER	
39	153383001	2	オクリダイカンザ	FEED BRACKET WASHER	
40	153384001	2	リテーナークミ	RETAINER ASSY	
40-1	153385000	2	リテーナ	RETAINER	
40-2	071023850	22	コウキュウ3/32	BEARING BALL 3/32	
41	S41234001	1	オクリダイアンナイジク	FEED BAR GUIDE SHAFT	
42	071047650	2	コウキュウ3/16	BEARING BALL, 3/16	
43	S41235001	1	ヨコオクリカクコマ433	TACK LENGTH REGULATOR BLOCK	
45	153391001	1	オクリダイカバー L	FEED GUIDE COVER (L)	
46	S41237001	1	カバーササエダイ	COVER SUPPORT STAND	
47	062670512	1	ナベコ357-40X5	SCREW, PAN SM3.57-40X5	
48	025060232	2	ヒラザガネチューブ6	WASHER, PLAIN M6	
49	017761412	2	ボルト5.95X14	BOLT, SM 5.95X14	
50	017680512	2	ボルト4.37X5	BOLT, SM 4.37X5	
51	153035000	1	オサエウデフェルト	PRESSER ARM FELT	
52	017680512	2	ボルト4.37X5	BOLT, SM 4.37X5	
53	S41352001	2	オサエブランク 433-1 (P=1)	WORK CLAMP PRESSER BLANK 433-1 (P=1)	
54	S41354001	2	オクリイタブランク 433-1 (P=1)	FEED PLATE BLANK 433-1 (P=1)	
<オプションパーツ/OPTION PARTS>					
53	S41353001	2	オサエブランク 433-2 (P=1.5)	WORK CLAMP PRESSER BLANK 433-2 (P=1.5)	
54	S41355001	2	オクリイタブランク 433-2 (P=1.5)	FEED PLATE BLANK 433-2 (P=1.5)	

From the library of: Diamond Needle Corp

118-Z30-202

D. 押工上げ関係 / Presser foot lifter mechanism / Stoffhalterhebevorrichtung / Mécanisme de leveur du pinceur / Mecanismo del levantador de ménsula de trabajo

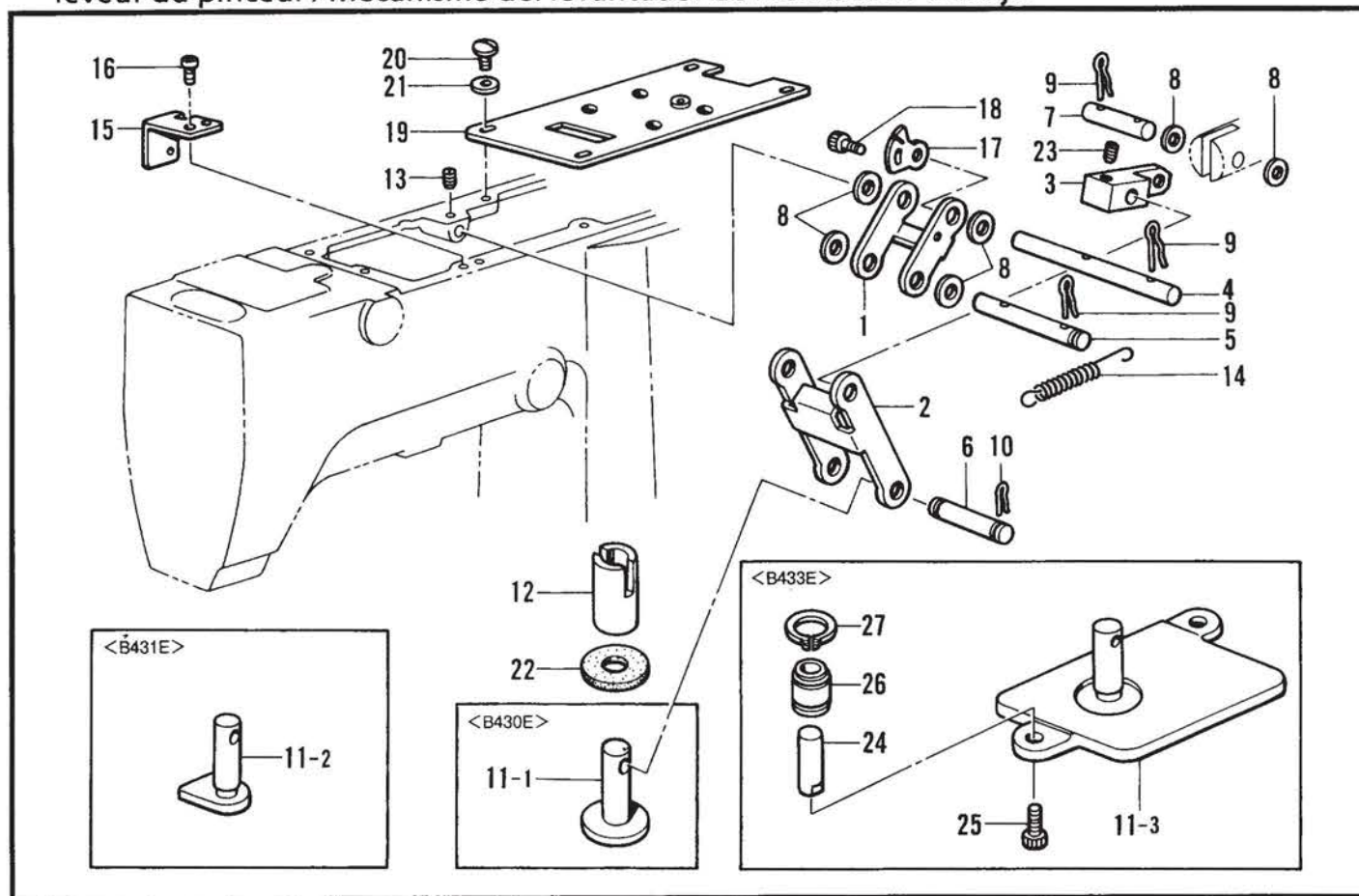

118-Z30-204

E. 糸払イ関係 / Thread wiper mechanism / Fadenwischvorrichtung / Mécanisme de tire-fil / Mecanismo del limpiador de hilo

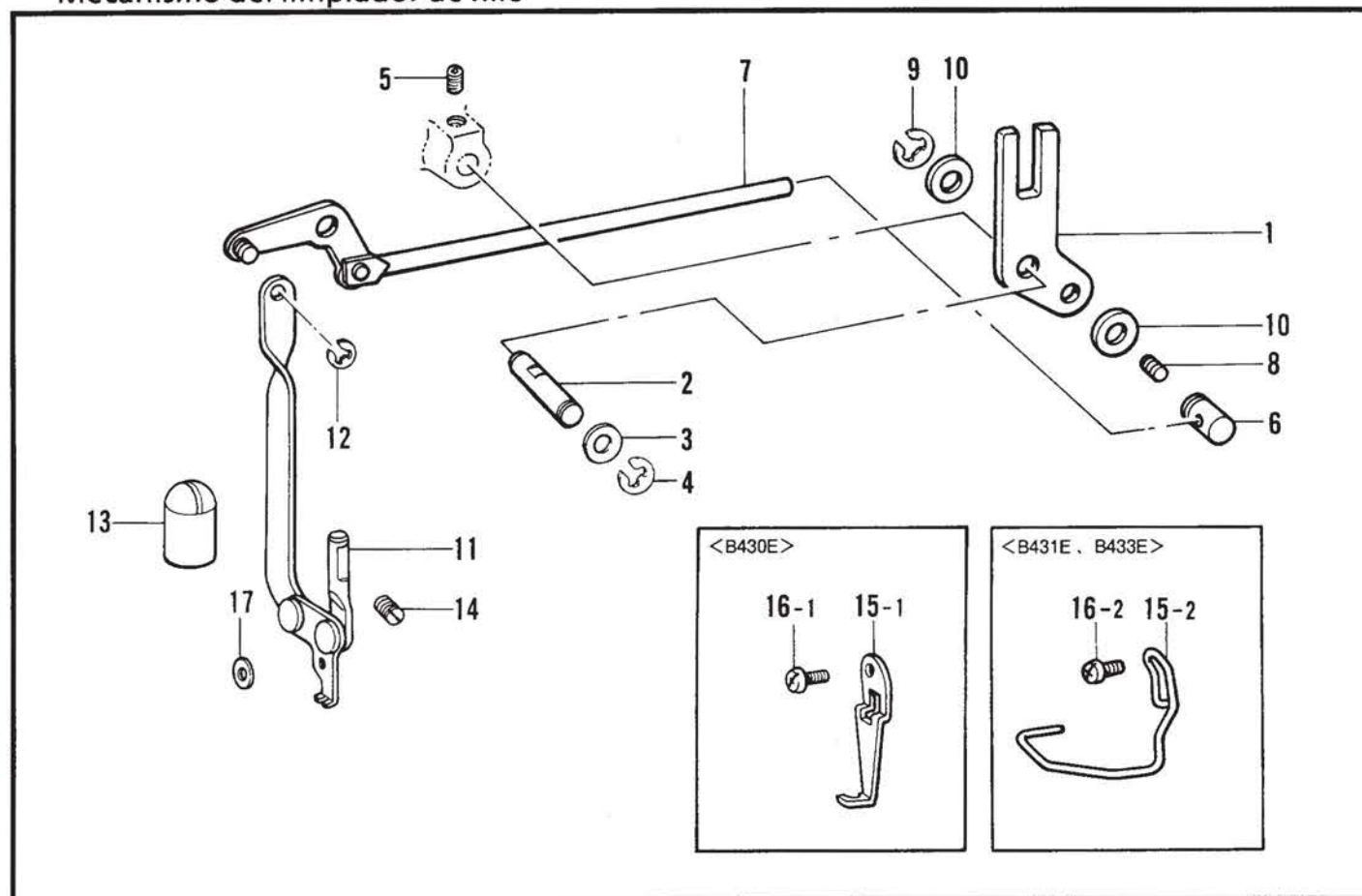

118-Z30-405

D. 押工上げ関係 / Presser foot lifter mechanism / Stoffhalterhebevorrichtung / Mécanisme de leveur du pinceur / Mecanismo del levantador de ménsula de trabajo

REF.NO.	CODE	Q'TY	ヒンメイ	NAME OF PARTS	RM
1	S37961001	1	リンクA	LINK A	
2	S37962001	1	リンクB	LINK B	
3	S37963001	1	リンクC	LINK C	
4	S37964001	1	リンクジクA	LINK SHAFT A	
5	S37965001	1	リンクジクB	LINK SHAFT B	
6	S37966001	1	リンクジクC	LINK SHAFT C	
7	S37967001	1	リンクジクD	LINK SHAFT D	
8	100281001	6	ザガネ	WASHER	
9	S37968001	6	スナツピン8	SNAP PIN	
10	S19662001	2	スナツピン5	SNAP PIN	
12	S37970050	1	オサエイタヨウメタル	BUSH FOR PRESSER PLATE	
13	014680622	1	アナトメネジ4.37クボミ	SET SCREW, SOCKET (CP) M4.37	
15	S37971001	1	センサダイ	SENSOR MOUNT	
16	062680612	1	ナベコ4.37-40X6	SCREW, PAN SM4.37-40X6	
17	S37972001	1	センサカンチイタ	SENSOR PERCEIVE PLATE	
18	018300636	1	アナボルト3X6	BOLT, SOCKET M3X6	
19	S37973001	1	ソレノイドトリツケイタ	SOLENOID SETTING PLATE	
20	106629002	4	シメネジ4.37	SCREW, SM4.37	
21	100645003	4	ザガネ	WASHER	
22	S37974000	1	オサエアゲストツバーゴム	PRESSER BAR LIFTER LEVER RUBBER	
23	013781012	2	トメネジ6.35クボミ	SET SCREW, (CP) SM6.35	
<B430E>					
11-1	S37969001	1	オサエイタ	PRESSER PLATE	
14	S10105001	1	リンクモドシバネ	SPRING	
<B431E>					
11-2	S41231001	1	オサエイタ431	PRESSER PLATE, 431	
14	S10105001	1	リンクモドシバネ	SPRING	
<B433E>					
11-3	S41238001	1	オサエイタL	PRESSER PLATE, L	
14	S40926001	1	リンクモドシバネB	SPRING B	
24	S41239001	2	アンナイジク12	GUIDE SHAFT, 12	
25	018501036	2	アナボルト5X10	BOLT, SOCKET M5X10	
26	S10103001	2	ボールブッシュ	BALL BUSH	
27	048200142	2	トメワジクヨウC20	RETAINING RING, C20	

118-Z30-204

E. 糸払イ関係 / Thread wiper mechanism / Fadenwischvorrichtung / Mécanisme de tire-fil / Mecanismo del limpiador de hilo

REF.NO.	CODE	Q'TY	ヒンメイ	NAME OF PARTS	RM
1	S38023001	1	ワイバークドレバー	THREAD WIPER DRIVING LEVER	
2	152822001	1	ワイバーク	THREAD WIPER SHAFT	
3	025770232	1	ヒラザガネチヨウ6.35	WASHER, PLAIN M 6.35	
4	048040342	1	トメワE4	RETAINING RING, E4	
5	014680622	1	アナトメネジ4.37クボミ	SET SCREW, SOCKET (CP) SM4.37	
6	S38024001	1	ワイバークツドジク	THREAD WIPER ROD SHAFT	
7	S38025001	1	ワイバークツドクミ	THREAD WIPER ROD ASSY	
8	014680622	1	アナトメネジ4.37クボミ	SET SCREW, SOCKET (CP) SM4.37	
9	048060342	1	トメワE6	RETAINING RING, E6	
10	116629001	2	ザガネ	WASHER	
11	152823001	1	ワイバークウデクミ	THREAD WIPER ARM ASSY	
12	048030342	1	トメワE3	RETAINING RING, E3	
13	152827009	1	オイルキリセン	OIL CAP	
14	014710522	1	アナトメネジ4.76クボミ	SET SCREW, SOCKET (CP) M4.76	
17	025350132	1	ヒラザガネシヨウ	WASHER, PLAIN S 3.5	
<B430E>					
11	152823001	1	ワイバークウデクミ	THREAD WIPER ARM ASSY	
15-1	156206001	1	ワイバークA	THREAD WIPER (A)	
16-1	062670512	1	ナベコ357-40X5	SCREW, PAN SM3.57-40X5	
<B431E>					
11	S41284001	1	ワイバークウデクミ	THREAD WIPER ARM ASSY	
15-2	S00926101	1	フィンガーガード	FINGER GUARD	
16-2	062670512	1	ナベコ357-40X5	SCREW, PAN M3.57-40X5	
<B433E>					
11	152823001	1	ワイバークウデクミ	THREAD WIPER ARM ASSY	
15-2	S00926101	1	フィンガーガード	FINGER GUARD	
16-2	062670512	1	ナベコ357-40X5	SCREW, PAN M3.57-40X5	

118-Z30-405

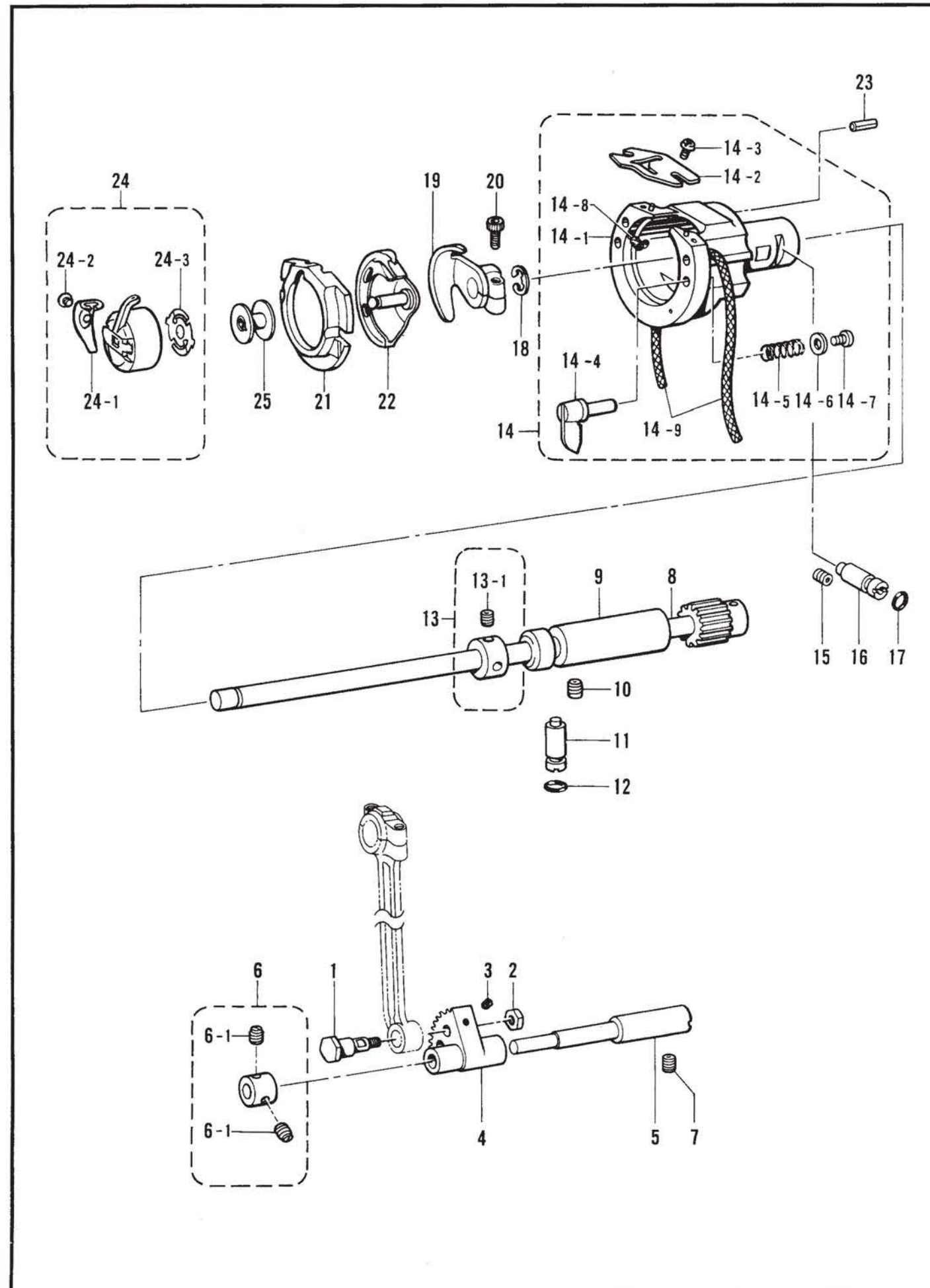

118-Z30-305

REF.NO.	CODE	Q'TY	品名	NAME OF PARTS	RM
1	141786001	1	クランクロッドダンネジ	CRANK ROD STUD SCREW	
2	100090004	1	ナット7.14	NUT, SM7.14	
3	014680622	1	アナトメネジ4.37クボミ	SET SCREW, SOCKET (CP) SM4.37	
4	152245001	1	ヨウドウギヤ	ROCK GEAR	
5	S37978051	1	ヨウドウギヤジク	ROCK GEAR SHAFT	
6	181995001	1	セットカラークミ	SET SCREW COLLAR ASSY	
6-1	101706001	2	トメネジ6.35	SET SCREW, SM6.35	
7	014760622	1	アナトメネジ5.95	SET SCREW, SOCKET (CP) SM5.95	
8	S37979101	1	シタジククミ	LOWER SHAFT ASSY	
9	S37981051	1	シタジクメタル	LOWER SHAFT BUSH	
10	014760622	1	アナトメネジ5.95	SET SCREW, SOCKET (CP) SM5.95	
11	152678001	1	カマチヨウセツジク	SHUTTLE HOOK ADJUST STUD	
12	081003670	1	リングPW3	O RING, PW3	
13	S03704002	1	セットカラークミ	SET SCREW COLLAR ASSY	
13-1	014770622	2	アナトメネジ6.35クボミ	SET SCREW, SOCKET (CP) SM6.35	
14	※	1	オオカマタイクミ	SHUTTLE RACE BASE ASSY	
14-1	※	1	オオカマタイ	SHUTTLE RACE BASE	
14-2	S02429101	1	カマイトアンナイ	SHUTTLE RACE THREAD GUIDE	
14-3	062660412	2	ナベコ318-40X4	SCREW, PAN SM3.18-40X4	
14-4	152683001	2	オオカマトリツケツメ	LARGE SHUTTLE HOOK SET CLAW	
14-5	152684101	2	オオカマトリツケバネ	SPRING	
14-6	402887001	2	ザガネ3.2	WASHER, 3.2	
14-7	062660712	2	ナベコ318-40X7	SCREW, PAN SM3.18-40X7	
14-8	153050000	2	オオカマタイフェルト	SHUTTLE RACE BASE FELT	
14-9	S02877000	2	クミヒモ4X4	WICK 4X4 (L=350)	
15	014760622	1	アナトメネジ5.95	SET SCREW, SOCKET (CP) SM5.95	
16	152678001	1	カマチヨウセツジク	SHUTTLE HOOK ADJUST STUD	
17	081003670	1	リングPW3	O RING, PW3	
18	048080342	1	トメワE8	RETAINING RING, E8	
19	152681201	1	ドライバー	DRIVER	
20	018501422	1	アナボルト5X14	BOLT, SOCKET M5X14	
21	※	1	オオカマ	LARGE SHUTTLE HOOK	
22	※	1	ナカカマ	INNER ROTARY HOOK	
23	120438001	1	ミゾツキピン	DOWEL PIN	
24	159610201	1	ボビンケースクミA	BOBBIN CASE ASSY (A)	
24-1	154339001	1	ボビンケースチヨウシバネ	TENSION SPRING	
24-2	154341001	1	ボビンケースバネネジ	SCREW	
24-3	159612001	1	クウテンボウシバネ	BOBBIN TENSION SPRING	
25	159613001	1	ボビン	BOBBIN	

From the library of: Diamond Needle Corp

118-Z30-305

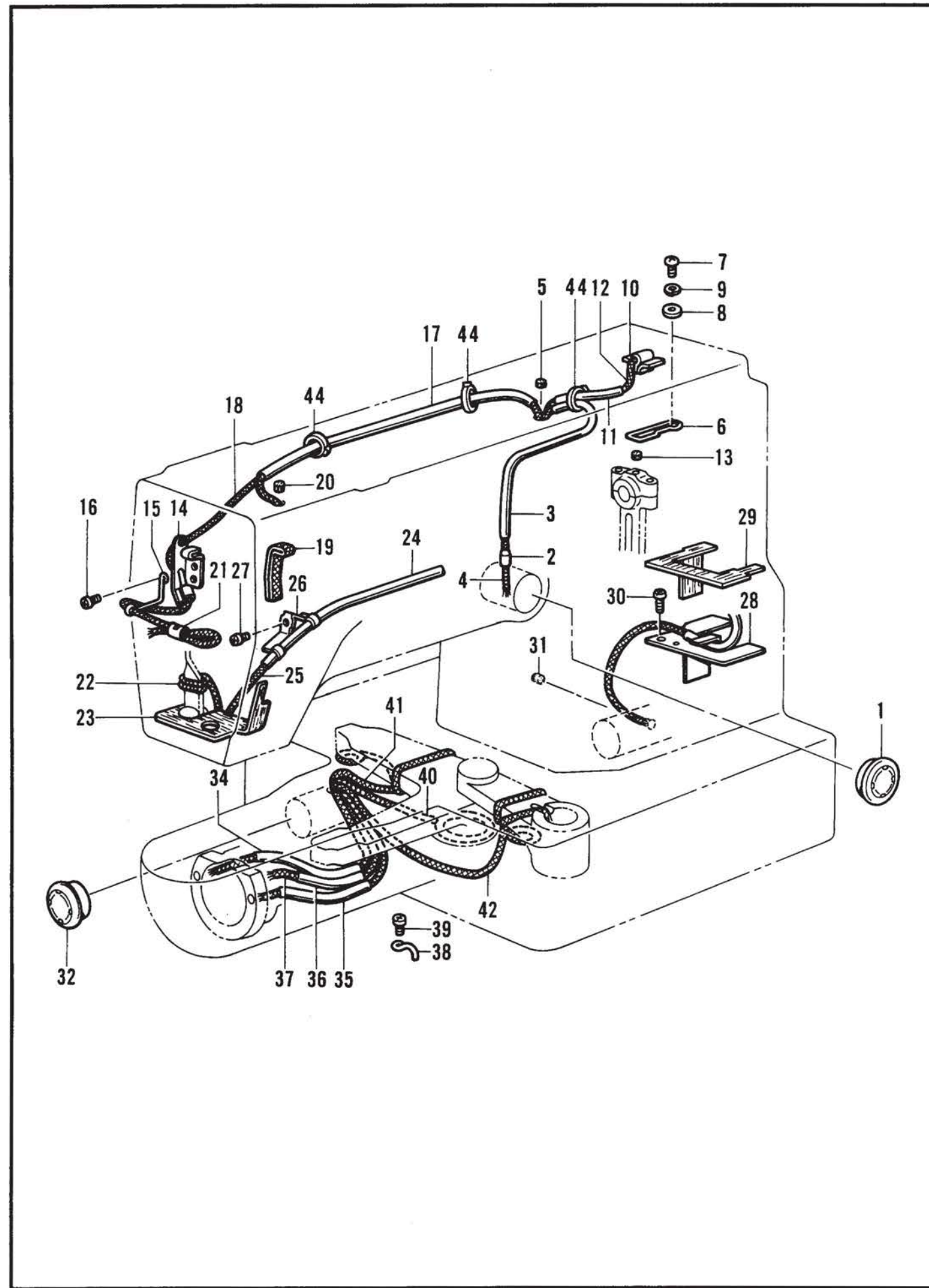

118-Z30-350

REF.NO.	CODE	Q'TY	品名	NAME OF PARTS	RM
1	152948001	1	オイルポットマド	OIL WINDOW	
2	S07333001	1	オイルクチパイプS	OIL FEEDING PIPE (S)	
3	S07456000	1	ビニールチューブ	OIL TUBE (L = 160)	
4	148738000	1	クミヒモ	WICK	
5	107149001	1	フェルト	FELT	
6	S37983001	1	ウワジクキウユササエ	WICK SUPPORT	
7	062680612	1	ナベコ4.37-40X6	SCREW, PAN SM4.37-40X6	
8	025680232	1	ヒラザガネチユウ4.37	WASHER, PLAIN SM4.37	
9	028680242	1	バネザガネ2-4.37	WASHER, SPRING 2 SM4.37	
10	S10478000	1	ロツドキウユフェルト	FELT	
11	S34986000	1	ビニールチューブ	OIL TUBE (L = 135)	
12	153920001	1	クミヒモ4X4	WICK 4X4 (L = 300)	
13	107149001	1	フェルト	FELT	
14	S21527001	1	テンビンキウユササエ	WICK SUPPORT	
15	S10162201	1	ハリボウヒモササエ	WICK SUPPORT	
16	060670512	1	バインド357-40X5	SCREW, BIND SM3.57-40X5	
17	S37984000	1	ビニールチューブ	OIL TUBE	
18	S18093100	1	クミヒモ4X4	WICK 4X4	
19	153562001	1	ヒラクミヒモ	FLAT WICK (L = 150)	
20	151927001	1	クラツチフェルト	CLUTCH FELT	
21	104567001	1	クミヒモササエ	WICK SUPPORT	
22	159565000	1	クミヒモ2.5X150	WICK (L = 150)	
23	S37985000	1	スイアゲフェルト	FELT	
24	S37986000	1	ビニールチューブ	OIL TUBE	
25	S18093100	1	クミヒモ4X4	WICK 4X4	
26	145547001	1	チューブホルダ	TUBE HOLDER	
27	062670512	1	ナベコ357-40X5	SCREW, PAN SM3.57-40X5	
28	S37987001	1	シタジクキウユササエ	FELT SUPPORT	
29	S37988000	1	シタジクキウユフェルト	FELT	
30	062680612	1	ナベコ4.37-40X6	SCREW, PAN SM4.37-40X6	
31	S09043000	1	フェルト	FELT	
32	152948001	1	オイルポットマド	OIL WINDOW	
34	S34983000	1	ビニールチューブ	OIL TUBE (L = 160)	
35	S34986000	1	ビニールチューブ	OIL TUBE (L = 135)	
36	S34982000	1	ビニールチューブ	OIL TUBE (L = 70)	
37	153920001	1	クミヒモ4X4	WICK 4X4 (L = 300)	
38	152969001	1	コードササエカネ	CORD SUPPORT	
39	062670512	1	ナベコ357-40X5	SCREW, PAN SM3.57-40X5	
40	148738000	1	クミヒモ	WICK	
41	148738000	1	クミヒモ	WICK	
42	152956001	1	クミヒモ4X4	WICK 4X4 (L = 500)	
44	228475000	3	ケツソクバンド1.9X80	BINDER	

From the library of: Diamond Needle Corp

118-Z30-350

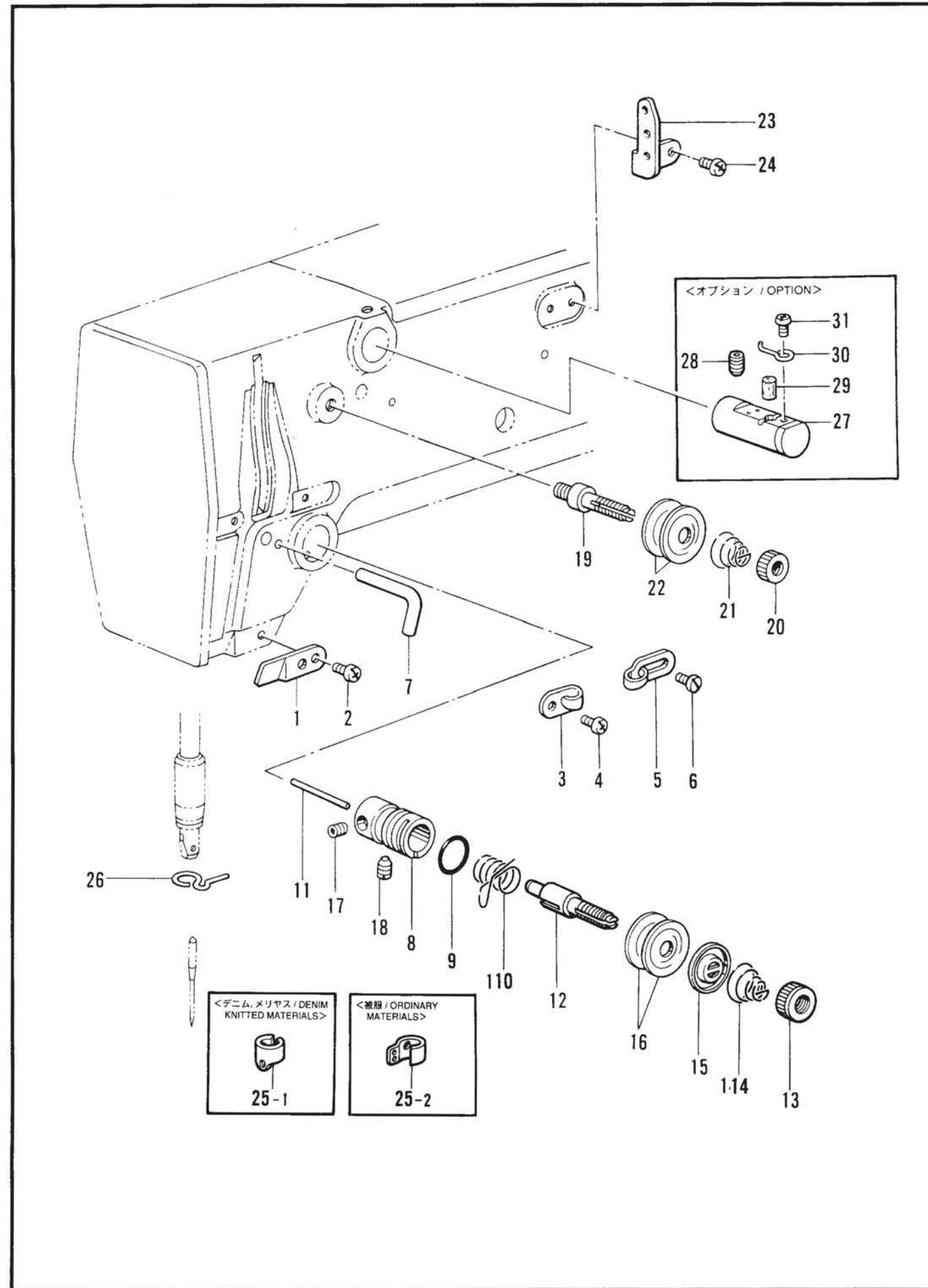

118-Z30-401

REF.NO.	CODE	Q'TY	ヒンメイ	NAME OF PARTS	RM
1	152869001	1	アームイトミチ	ARM THREAD GUIDE	
2	062710612	1	ナベコ476-32X6	SCREW, PAN SM4.76-32X6	
3	152870001	1	アームイトカケ	ARM THREAD GUIDE	
4	062670612	1	ナベコ357-40X6	SCREW, PAN SM3.57-40X6	
5	113316001	1	アームイトアンナイ	ARM THREAD GUIDE	
6	060670612	1	バインド357-40X6	SCREW, BIND SM3.57-40X6	
7	159224001	1	アームイトカケ	ARM THREAD GUIDE	
8	152872001	1	イトチヨウシダイ	TENSION BRACKET	
9	114294001	1	リング	O RING	
10	※	1	イトトリバネ	SPRING	
11	100400000	1	イトユルメピン	PIN	
12	100398001	1	イトチヨウシボウ	TENSION STUD	
13	100136001	1	イトチヨウシナツト	TENSION NUT	
14	※	1	イトチヨウシバネ	TENSION SPRING	
15	159805001	1	イトチヨウシサラオサエ	TENSION DISC PRESSER	
16	145446001	2	イトチヨウシサラ	TENSION DISC	
17	100402004	1	トメネジ3.57	SET SCREW, SM3.57	
18	103950003	1	トメネジ5.95	SET SCREW, SM5.95	
19	115186001	1	シュイトチヨウシボウ	MAIN THREAD TENSION STUD	
20	100136001	1	イトチヨウシナツト	TENSION NUT	
21	115188001	1	シュイトチヨウシバネ	TENSION SPRING	
22	145446001	2	イトチヨウシサラ	TENSION DISC	
23	152889001	1	ミツメイトカケ	THREAD RETAINER	
24	062670612	2	ナベコ357-40X6	SCREW, PAN SM3.57-40X6	
26	152891001	1	ハリボウメタルDイトアンナイ	NEEDLE BAR BUSH (D) THREAD GUIDE	
<オプションパーツ/OPTION PARTS>					
27	152881001	1	エキレイタイクミ	NEEDLE COOLER ASSY	
28	014680622	1	アナトメネジ4.37クボミ	SET SCREW, SOCKET (CP) SM4.37	
29	152883000	1	フェルト8X15.5	FELT 8X15.5	
30	152884001	1	エキレイイトカケ	NEEDLE COOLER THREAD GUIDE	
31	062670412	1	ナベコ357-40X4	SCREW, PAN SM3.57-40X4	
<デニム、メリヤス用/FOR DENIM, KNITTED MATERIALS>					
25-1	152890001	1	ハリボウイトアンナイA	NEEDLE BAR THREAD GUIDE (A)	
<被服用/FOR ORDINARY MATERIALS>					
25-2	S41222001	1	ハリボウイトアンナイB	NEEDLE BAR THREAD GUIDE (B)	

From the library of: Diamond Needle Corp

118-Z30-401

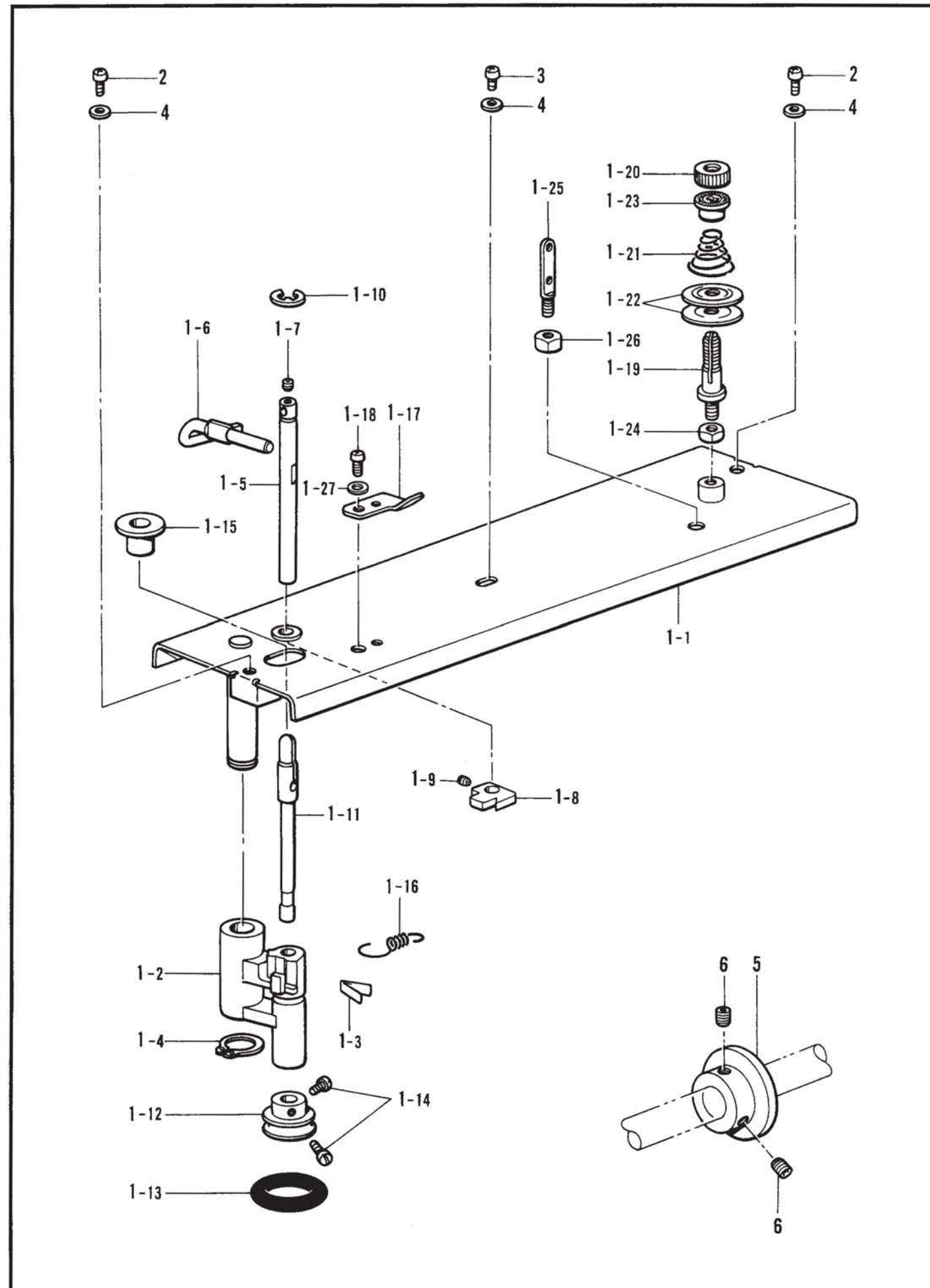

118-Z30-402

REF.NO.	CODE	Q'TY	ヒンメイ	NAME OF PARTS	RM
1-1	S37991009	1	ウワフタ	TOP COVER	
1-2	S37992000	1	イトマキウデ	BOBBIN WINDER ARM	
1-3	S37993000	1	イタバネ	PLATE SPRING	
1-4	048100142	1	トメワジクヨウC10	RETAINING RING, C10	
1-5	S37994001	1	イトマキツメジク	BOBBIN WINDER CLAW STUD	
1-6	S37995001	1	ボビンオサエ	BOBBIN PRESSER	
1-7	014679320	1	アナトメネジ3.57クボミ	SET SCREW, SOCKET (CP) M3.57	
1-8	S37996001	1	イトマキツメ	BOBBIN WINDER CLAW	
1-9	014680622	1	アナトメネジ4.37クボミ	SET SCREW, SOCKET (CP) SM4.37	
1-10	048050342	1	トメワE5	RETAINING RING, E5	
1-11	S37997001	1	イトマキジク	BOBBIN WINDER SHAFT	
1-12	154528001	1	イトマキクルマ	BOBBIN WINDER WHEEL	
1-13	120448001	1	ゴムワ	RUBBER RING	
1-14	120990001	2	アタマツキトメネジ4.37	SET SCREW, SM4.37	
1-15	S10174000	1	ホコリヨケイタ	DUST GUARD PLATE	
1-16	S37998001	1	イトマキウデバネ	SPRING	
1-17	152938001	1	メス	KNIFE	
1-18	062680512	1	ナベコ437-40X5	SCREW, PAN SM4.37-40X5	
1-19	159574101	1	イトチヨウシボウ	TENSION STUD	
1-20	100136001	1	イトチヨウシナツト	TENSION NUT	
1-21	144110001	1	シタルーバイトチヨウシバネ	THREAD TENSION ADJUST SPRING	
1-22	145446001	2	イトチヨウシサラ	TENSION DISC	
1-23	144105000	1	チヨウシバネウエザガネ	FLANGE WASHER, TENSION SPRING	
1-24	021680202	1	ナツト2シユ4.37	NUT, 2 SM4.37	
1-25	141590001	1	イトトオシボウ	THREADING BAR (U)	
1-26	100022004	2	ナツト5.95	NUT, SM5.95	
1-27	025680232	1	ヒラザガネチユウ4.37	WASHER, PLAIN SM4.37	
2	062681212	2	ナベコ437-40X12	SCREW, PAN SM4.37-40X12	
3	062680812	1	ナベコ437-40X8	SCREW, PAN SM4.37-40X8	
4	025680232	3	ヒラザガネチユウ4.37	WASHER, PLAIN SM4.37	
5	S10176000	1	イトマキプーリ	BOBBIN WINDER PULLEY	
6	014760622	2	アナトメネジ5.95	SET SCREW, SOCKET (CP) SM5.95	

From the library of: Diamond Needle Corp

118-Z30-402

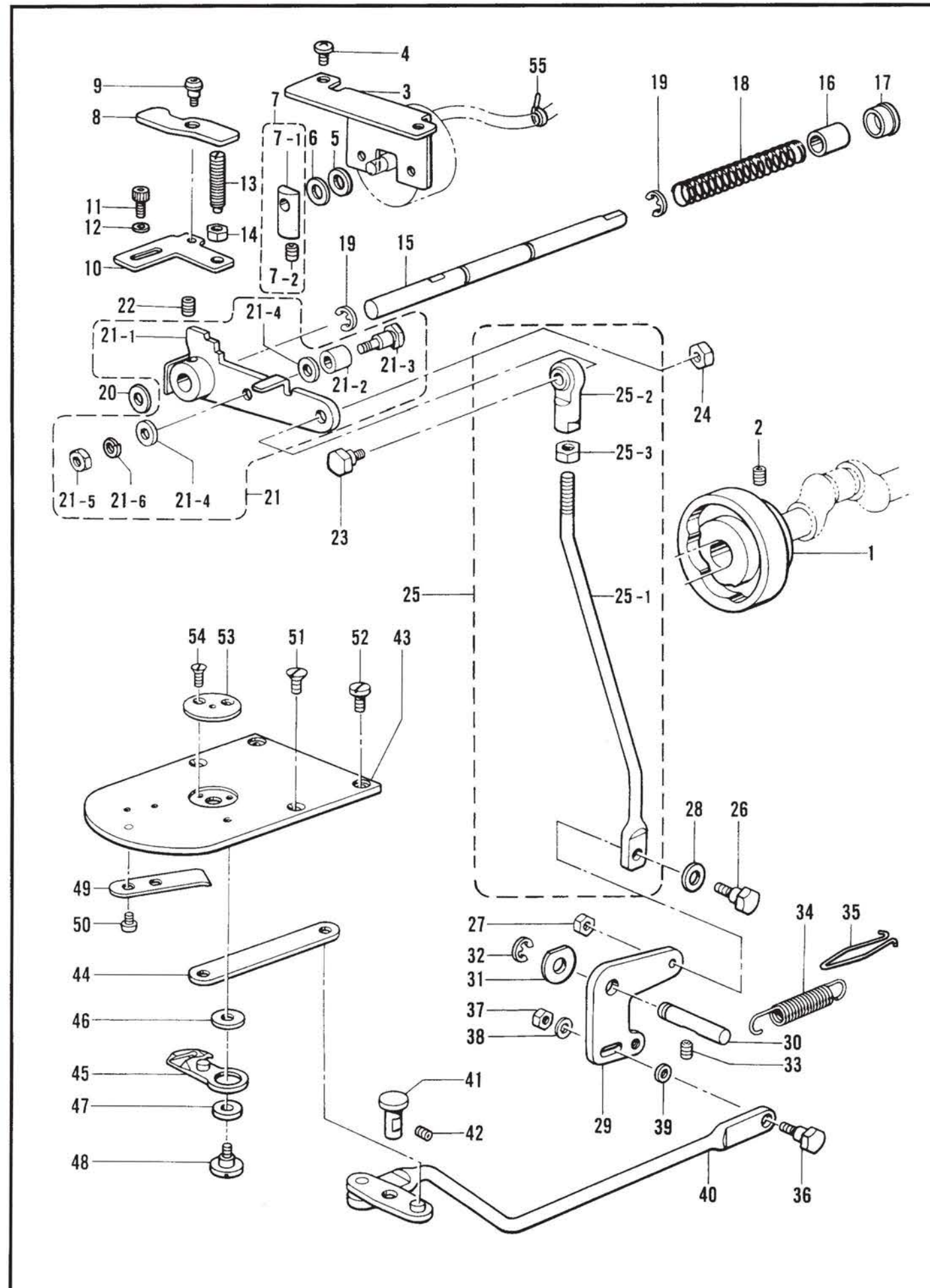

118-Z30-403

REF.NO.	CODE	Q'TY	ヒンメイ	NAME OF PARTS	RM
1	S38001001	1	イトキリカム	THREAD TRIMMER CAM	
2	014770622	2	アナトメネジ6.35クボミ	SET SCREW, SOCKET (CP) SM6.35	
3	S38002001	1	ソレノイドトリツケイタ	SOLENOID SET PLATE	
4	060680712	2	バインド437-40X7	SCREW, BIND SM4.37-40X7	
5	154599000	1	ソレノイドクツシヨン	SOLENOID CUSHION	
6	S02652001	1	ザガネ	WASHER	
7	S23836001	1	ソレノイドレバークミ	SOLENOID LEVER ASSY	
7-1	S02654001	1	ソレノイドレバ	SOLENOID LEVER	
7-2	014680622	1	アナトメネジ4.37クボミ	SET SCREW, SOCKET (CP) SM4.37	
8	S38003001	1	クドウレバ	PUSHING LEVER DRIVING LEVER	
9	145478101	1	ダンネジ4.76	SHOULDER SCREW, SM4.76	
10	S38004001	1	クドウレバ	DRIVING LEVER STOPPER (MARK1)	
10	S38004002	1	クドウレバ	DRIVING LEVER STOPPER (MARK2)	
10	S38004003	1	クドウレバ	DRIVING LEVER STOPPER (MARK3)	
11	018681022	2	アナボルト4.37X10	BOLT, SOCKET SM4.37X10	
12	025680132	2	ヒラザガネシヨウ4.37	WASHER, PLAIN S 4.37	
13	159905001	1	トメヌイチヨウセツネジ	ADJUST SCREW	
14	106147002	1	ナツト7.94	NUT, SM7.94	
15	S38005001	1	クドウレバ	DRIVING LEVER SHAFT	
16	231071001	1	メタル8X15	BUSH 8X15	
17	117934009	1	メクラセン	OIL CAP	
18	S10189001	1	クドウジクモドシバネ	SPRING	
19	048070342	2	トメワE7	RETAINING RING, E7	
20	154596000	1	イトキリカムレバークツシヨン	CUSHION	
21	S38006001	1	イトキリクドウレバークミ	THREAD TRIMMER DRIVING LEVER ASSY	
21-1	S38007001	1	イトキリクドウレバ	THREAD TRIMMER DRIVING LEVER	
21-2	153597001	1	シタイトサバキカラー	LOWER THREAD RETAINER COLLAR	
21-3	S30033001	1	ダンネジ3.57	SHOULDER SCREW, SM3.57	
21-4	148813001	2	ザガネ	WASHER	
21-5	106129002	1	ナツト3.57	NUT, SM3.57	
21-6	028350242	1	バネザガネ2-3.5	WASHER, SPRING 2-3.5	
22	014770622	1	アナトメネジ6.35クボミ	SET SCREW, SOCKET (CP) SM6.35	
23	S02354001	1	タマツギテダンネジB	STUD SCREW (B)	
24	100022005	1	ナツト5.95	NUT, SM5.95	
25	S38008001	1	イトキリロッドクミ	THREAD TRIMMER ROD ASSY	
25-1	S38009001	1	イトキリロッド	THREAD TRIMMER ROD	
25-2	S07512001	1	タマツギテRクミ	ROUND JOINT (R) ASSY	
25-3	100022005	1	ナツト5.95	NUT, SM5.95	
26	110233001	1	ダンネジ4.76	STUD SCREW 4.76	
27	110161004	1	ナツト4.76	NUT, SM4.76	
28	109893002	1	ザガネ	WASHER	
29	S38010001	1	イトキリレバ	THREAD TRIMMER LEVER	
30	S10195001	1	イトキリレバ	LEVER SHAFT	
31	110367001	1	ザガネ	WASHER, PLAIN SPECIAL 8	
32	048060342	1	トメワE6	RETAINING RING, E6	
33	014760622	1	アナトメネジ5.95	SET SCREW, SOCKET (CP) SM5.95	
34	S38011001	1	イトキリモドシバネ	THREAD TRIMMER RETURN SPRING	
35	158940001	1	バネカケ	SPRING HOOK	
36	110233001	1	ダンネジ4.76	STUD SCREW 4.76	
37	110161004	1	ナツト4.76	NUT, SM4.76	
38	153484001	1	ザガネ4.76	WASHER, PLAIN SM4.76	
39	025680232	1	ヒラザガネチヨウ4.37	WASHER, PLAIN SM4.37	
40	S38012001	1	レンカンレバークミ	CONNECTING ROD LEVER ASSY	
41	S10202101	1	レンカンレバ	CONNECTING ROD LEVER SHAFT	
42	014680422	1	アナトメネジ4.37クボミ	SET SCREW, SOCKET (CP) SM4.37	
43	S38015001	1	ハリイタ	NEEDLE PLATE	
44	S38016001	1	イトキリレンカン	THREAD TRIMMER CONNECTING ROD	
46	S10208001	1	イドウハカンザT=0.4	WASHER T=0.4	

From the library of: Diamond Needle Corp

118-Z30-403

K. 糸切り関係 / Thread trimmer mechanism / Fadenabschneidevorrichtung / Mécanisme de coupe-fil / Mecanismo de la cortadura de hiros

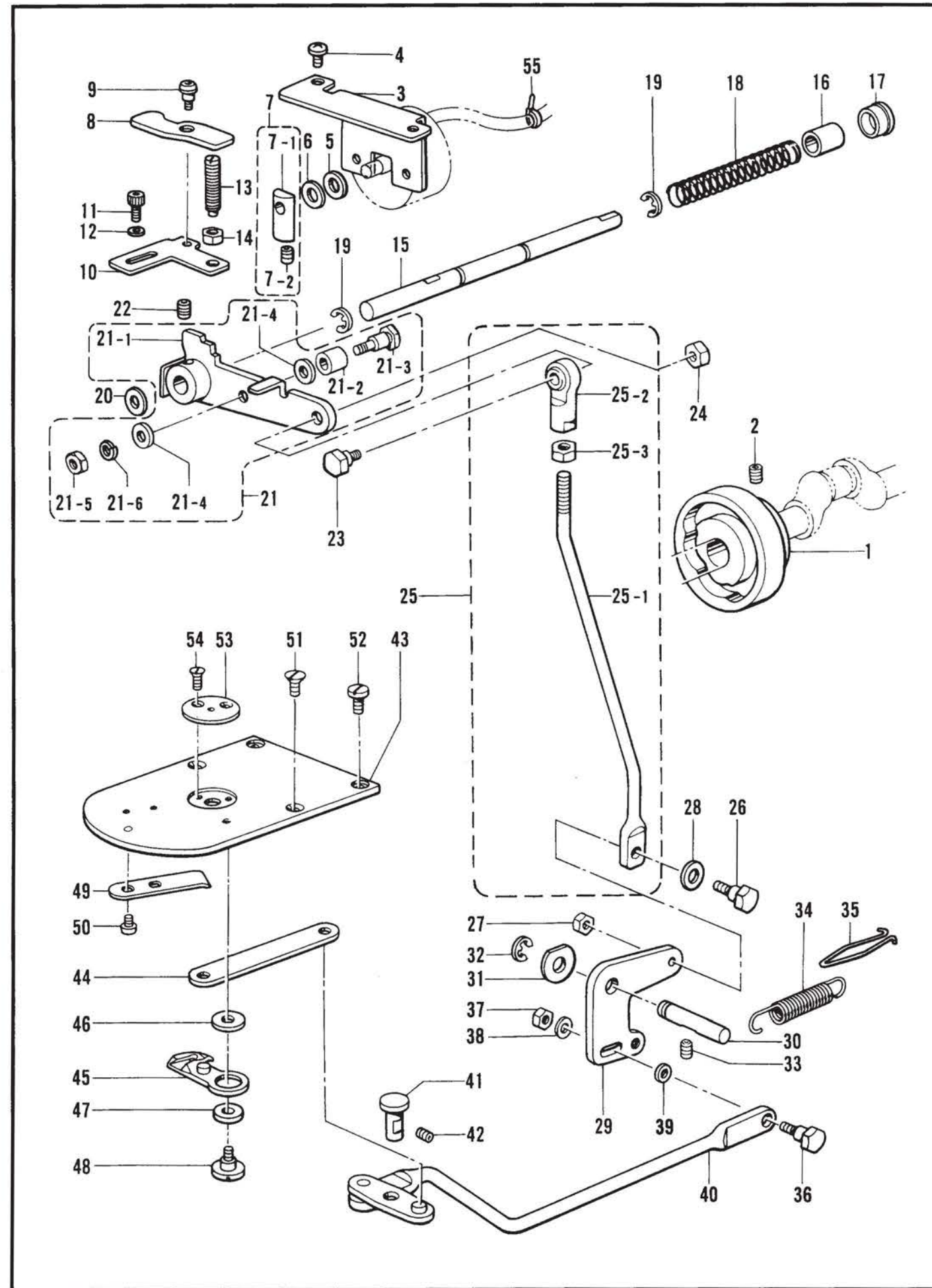

118-Z30-403

K. 糸切り関係 / Thread trimmer mechanism / Fadenabschneidevorrichtung / Mécanisme de coupe-fil / Mecanismo de la cortadura de hiros

REF.NO.	CODE	Q'TY	ヒンメイ	NAME OF PARTS	RM
46	S10208002	1	イドウハカンザ T=0.5	WASHER T=0.5	
46	S10208003	1	イドウハカンザ T=0.6	WASHER T=0.6	
47	S00705001	1	イドウハカラー	MOVABLE COLLAR	
48	S10209101	1	シメネジ4.37	SCREW 4.37	
49	S10210101	1	コテイハ	FIXED KNIFE	
50	111140002	2	シメネジ2.38	SCREW, SM2.38	
51	100032004	2	サラネジ4.37	SCREW, FLAT SM4.37	
52	153208002	2	シメネジ4.37	SCREW, SM4.37	
53	※	1	ハリアナイタ	NEEDLE HOLE PLATE	
54	100360003	2	サラネジ2.38	SCREW, FLAT SM2.38	
55	228475000	1	ケツソクバンド1.9X80	BINDER	
<B430E,B433E>					
45	S10205001	1	イドウハクミ	MOVABLE KNIFE ASSY	
<B431E>					
45	S40934001	1	イドウハクミ	MOVABLE KNIFE (L) ASSY	

From the library of: Diamond Needle Corp

118-Z30-403

L. 糸締メ関係 / Thread nipper mechanism / Fadenspannvorrichtung / Mécanisme de pince-fil / Mecanismo de la mordaza para hilo

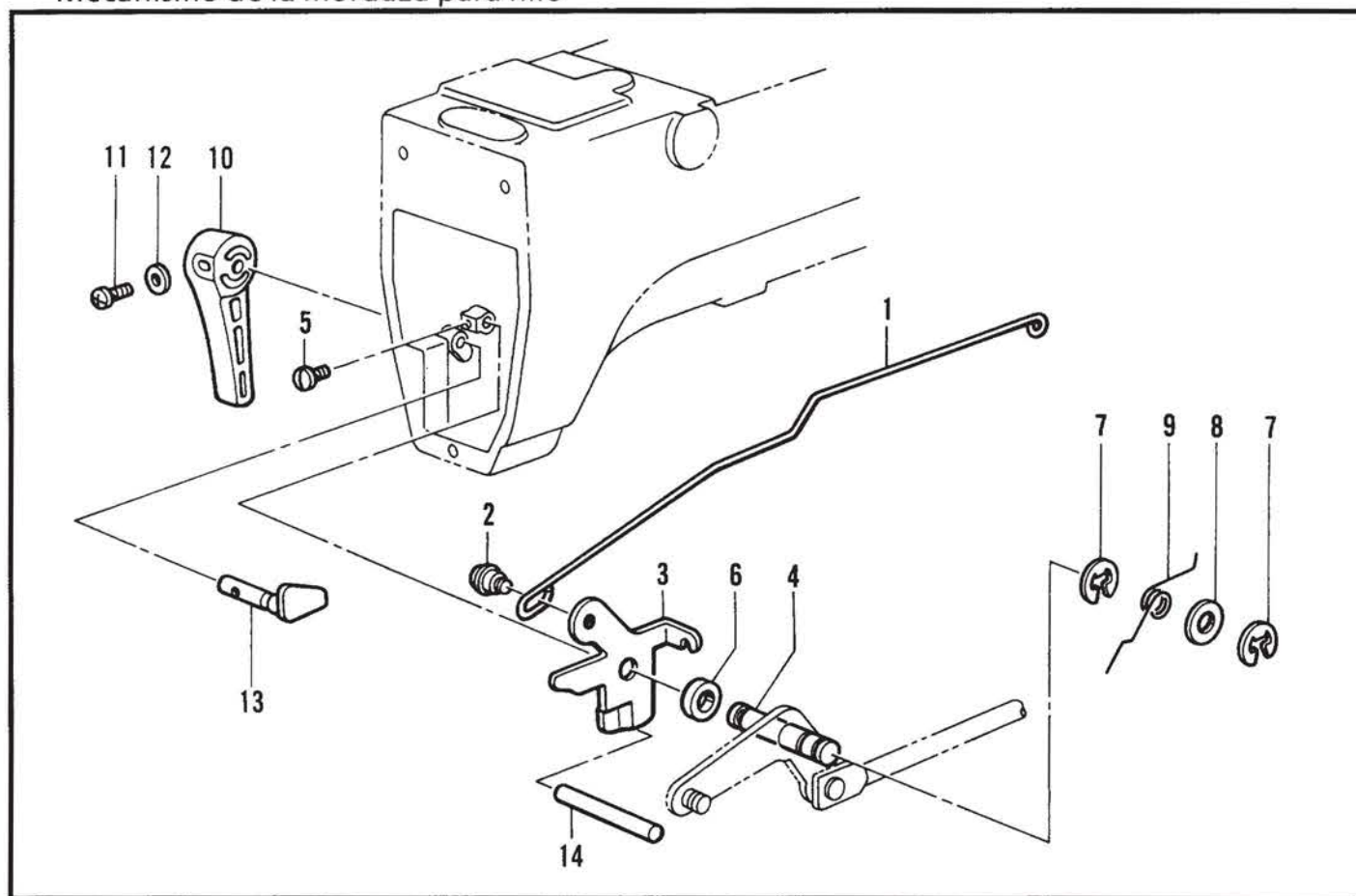

118-Z30-406

M. 針位置検出器関係 / Synchronizer / Synchronisator / Synchronisateur / Sincronizador

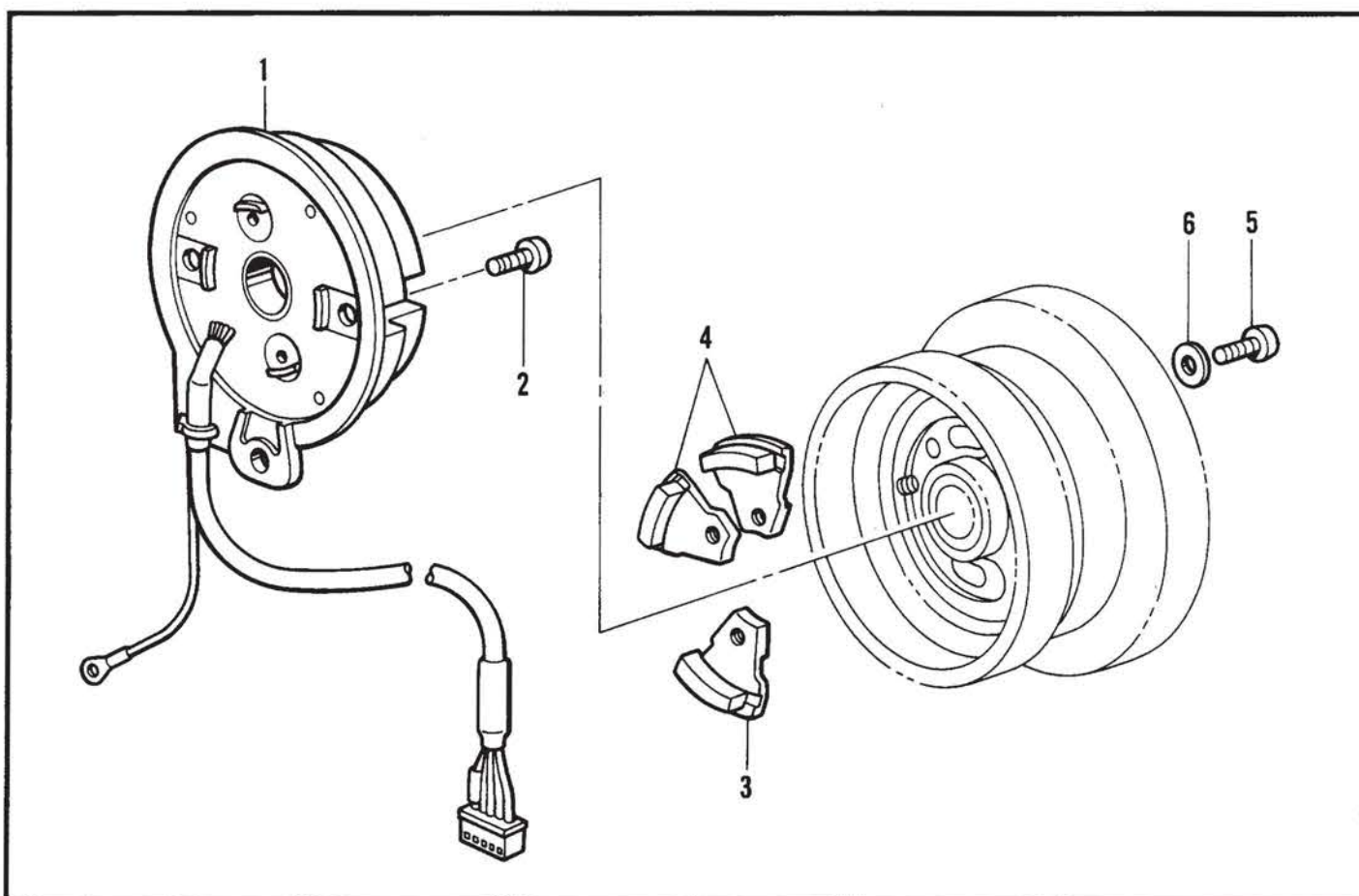

118-Z30-501

L. 糸締メ関係 / Thread nipper mechanism / Fadenspannvorrichtung / Mécanisme de pince-fil / Mecanismo de la mordaza para hilo

REF.NO.	CODE	Q'TY	ヒンメイ	NAME OF PARTS	RM
1	S38031001	1	イトユルメロッド	TENSION RELEASE ROD	
2	145478101	2	ダンネジ4.76	SHOULDER SCREW, SM4.76	
3	S38032001	1	イトユルメレバー	TENSION RELEASE LEVER	
4	145474101	1	オサエアゲレバージク	PRESSER BAR LIFTER LEVER SHAFT	
5	S01998001	1	アタマツキトメネジ3.57	SET SCREW, SM3.57	
6	S38033001	1	カラー13	COLLAR 13	
7	048040342	2	トメワE4	RETAINING RING, E4	
8	109763002	1	ザガネ	WASHER	
9	145475101	1	オサエアゲレバーバネ	SPRING	
10	S31006001	1	オサエアゲテコ	PRESSER BAR LIFTER LEVER	
11	062351216	1	ナベコ35X12	SCREW, PAN M3.5X12	
12	102707001	1	ザガネ	WASHER	
13	S31952001	1	オサエアゲクランク	PRESSER BAR LIFTER CRANK	
14	S10239001	1	イトユルメボウ	TENSION RELEASE BAR	

118-Z30-406

M. 針位置検出器関係 / Synchronizer / Synchronisator / Synchronisateur / Sincronizador

REF.NO.	CODE	Q'TY	ヒンメイ	NAME OF PARTS	RM
1	S38072101	1	シンクロナイザクミ	SYNCHRONIZER ASSY	
2	062400806	2	ナベコ4X8	SCREW, PAN M4X8	
3	S38080001	1	ハリシタジシャクミ	NEEDLE DOWN MAGNET ASSY	
4	S38082001	2	ハリウエジシャクミ	NEEDLE UP MAGNET ASSY	
5	062681412	3	ナベコ437-40X14	SCREW, PAN SM4.37-40X14	
6	025680132	3	ヒラザガネシヨウ4.37	WASHER, PLAIN S 4.37	

118-Z30-501

N1. コントロールボックス関係 / Control box mechanism / Schaltkasten / Mécanisme du boîtier de contrôle / Mecanismo de la caja de controles

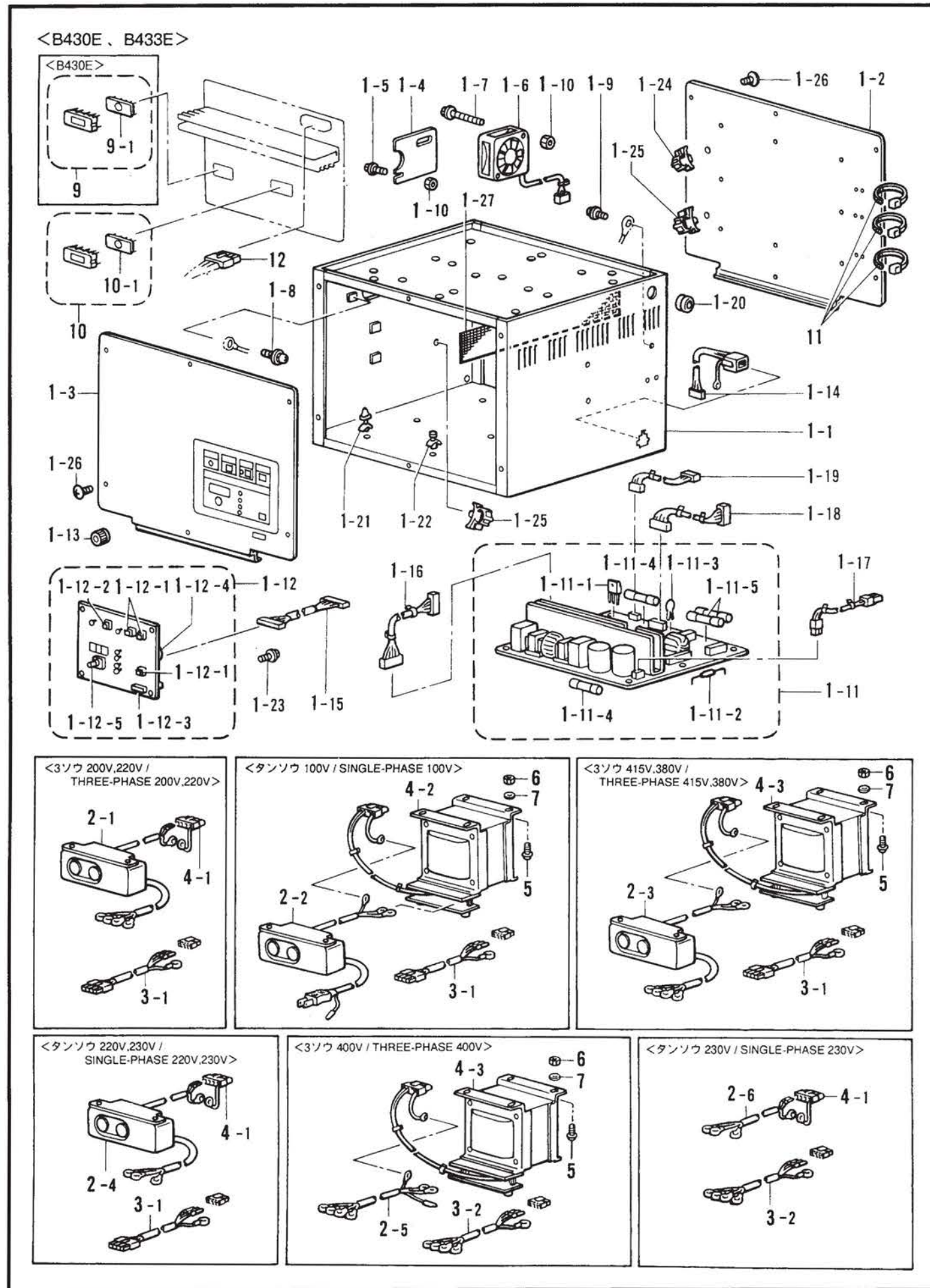

118-Z30-502

N1. コントロールボックス関係 / Control box mechanism / Schaltkasten / Mécanisme du boîtier de contrôle / Mecanismo de la caja de controles

REF.NO.	CODE	Q'TY	ヒンメイ	NAME OF PARTS	RM
<B430E, B433E>					
1	S38087009	1	ボックス	BOX ASSY	
1-1	S38088009	1	デンゲンボックス	POWER SUPPLY BOX	
1-2	S38089009	1	メインキバントリツケイタ	MAIN P.C. BOARD MOUNTING PLATE	
1-3	S38090009	1	パネルトリツケイタクミ	PANEL MOUNTING ASSY	
1-4	S38093000	1	コードオサエイタ	CORD PRESSER PLATE	
1-5	0A5401206	2	+ナベザクミ 4X12DB	SCREW, PAN (WASHER) M4X35DB	
1-6	S38094100	1	DCファンモータクミ	DC FAN MOTOR ASSY	
1-7	0A5403506	2	+ナベザクミ 4X35DB	SCREW, PAN (WASHER) M4X35DB	
1-8	0A5400806	1	+ナベザクミ 4X8DB	SCREW, PAN (WASHER) M4X8DB	
1-9	0A5401206	1	+ナベザクミ 4X12DB	SCREW, PAN (WASHER) M4X35DB	
1-10	021400206	4	2シユナツト4	NUT, 2 M4	
1-11	S38095001	1	デンゲンキバンクミ	POWER SUPPLY CIRCUIT BOARD ASSY	
1-11-1	S38200000	2	MOSFET25K1938	MOSFET25K1938	
1-11-2	232384001	1	SアブソバDSA362MA	SURGE ABSORBER	
1-11-3	S38201000	2	バリスタV14D471	VARISTOR	
1-11-4	S08030000	2	Gヒユーズ5AFB	G FUSE (5AFB)	
1-11-5	157219000	2	カンヒユーズ5A-D	FUSE 5A-D	
1-12	S38102001	1	パネルキバンクミ	PANEL CIRCUIT BOARD ASSY	
1-12-1	S30260002	3	SWDP1-100	SWDP1-100	
1-12-2	S30260003	1	SWDP1-100	SWDP1-100	
1-12-3	U16693000	1	DIPスイッチDSS808-1	DIP SWITCH: DSS808-1	
1-12-4	S30280000	1	ブザーPKB24SPC36	BUZZER PKB24SPC36	
1-12-5	S38104000	1	エンコーダEVQVEMF01	ENCODER EVQVEMF01	
1-13	S02907000	1	ツマミ	DIAL	
1-14	S38105000	1	フットSWコードクミ	FOOT SW CORD ASSY	
1-15	S38106000	1	パネルケーブルクミ	PANEL CABLE ASSY	
1-16	S38107000	1	セイギヨデンゲンコード	CONTROL POWER SUPPLY CORD	
1-17	S38108000	1	モータデンゲンコード	MOTOR POWER SUPPLY CORD	
1-18	S38109000	1	ゲートデンゲンコード	GATE POWER SUPPLY CORD	
1-19	S38110000	1	PERコード	PER CORD	
1-20	S11949000	2	ゴムブツシュ	RUBBER BUSH	
1-21	S00554000	16	サポート6NS	SUPPORT 6NS	
1-22	S38111000	1	サポート6S	SUPPORT 6S	
1-23	0A4300605	4	+ナベザクミ 3X6DA	SCREW, PAN (WASHER) M3X6DA	
1-24	150357001	1	コードクランプ13	CORD CLAMP (13-L)	
1-25	S09141000	2	コードクランプ16L	CORD CLAMP (16-L)	
1-26	008400604	12	+トラスコ4X6	SCREW, TRUSS M4X6	
1-27	S38116000	1	ボウジンアミ	FRAGMENT PROTECTOR NET	
10	S38131000	1	PROMモータクミ	PROM MOTOR ASSY	
10-1	S38143000	1	CM0SLSI27C512	CM0SLSI27C512	
11	228475000	8	ケツソクバンド1.9X80	BINDER	
12	S16568000	1	コネクタ3191-03R1	CONNECTOR (3191-03R1)	
<B430E>					
9	S38130000	1	PROMセイギヨクミ	PROM CONTROL ASSY	
9-1	S38143000	1	CM0SLSI27C512	CM0SLSI27C512	

From the library of: Diamond Needle Corp

118-Z30-502

N1. コントロールボックス関係 / Control box mechanism / Schaltkasten / Mécanisme du boîtier de contrôle / Mecanismo de la caja de controles

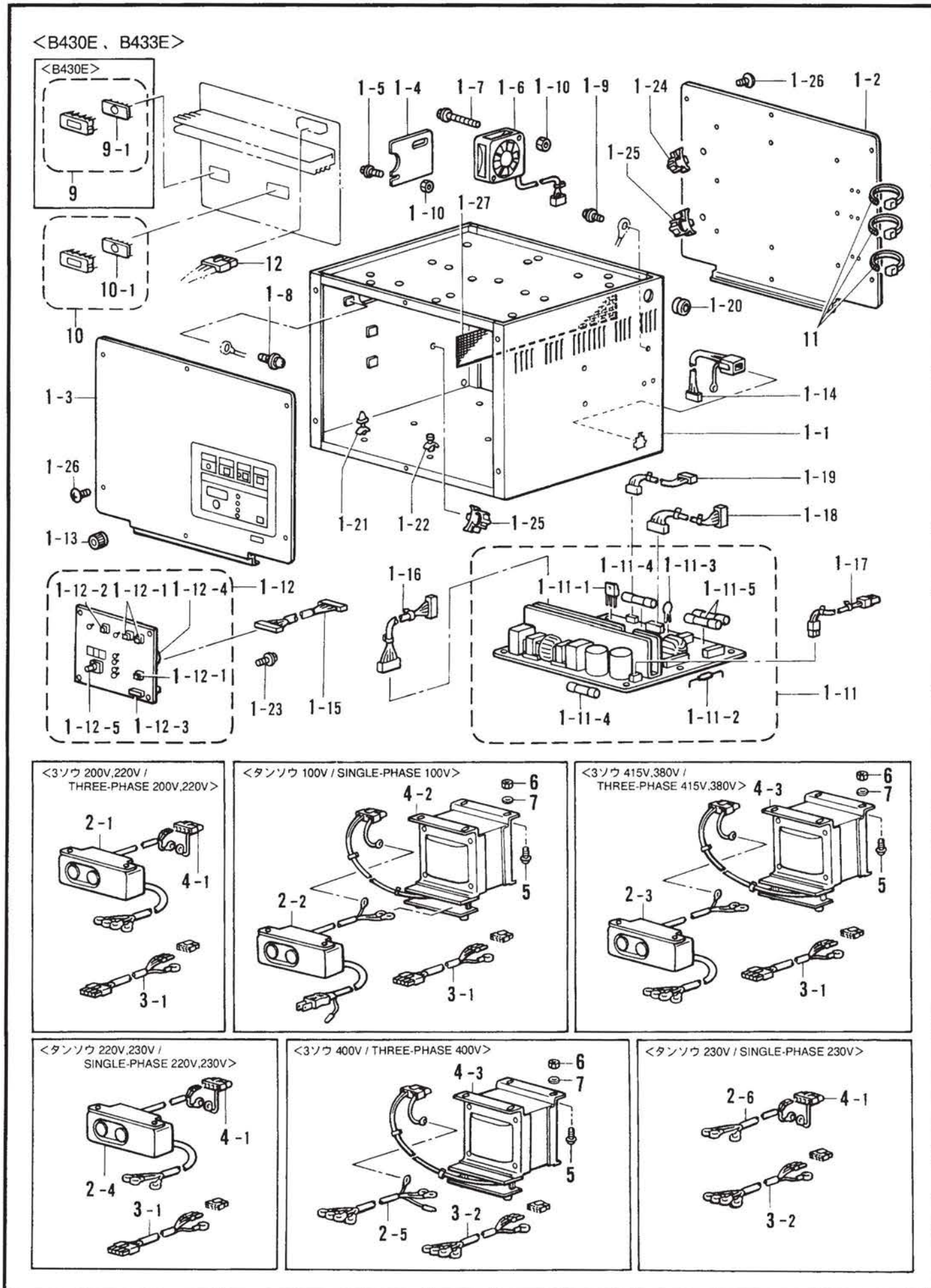

118-Z30-502

N1. コントロールボックス関係 / Control box mechanism / Schaltkasten / Mécanisme du boîtier de contrôle / Mecanismo de la caja de controles

REF.NO.	CODE	Q'TY	ヒンメイ	NAME OF PARTS	RM
<B430E, B433E>					
<ボックスソウクミAヨウ/ FOR POWER SUPPLY BOX ASSY (A)>					
<サンソウ 200V, 220V/THREE-PHASE 200V, 220V>					
2-1	S38112001	1	デンゲンSWクミA	POWER SUPPLY SW ASSY (A)	
3-1	S38121000	1	モーターケーブルクミ	MOTOR CABLE	
4-1	S38123000	1	ACINコネクタクミ	ACIN CONNECTOR ASSY	
<ボックスソウクミBヨウ/ FOR POWER SUPPLY BOX ASSY (B)>					
<タンソウ 100V/SINGLE-PHASE 100V>					
2-2	S38114000	1	デンゲンSWクミB	POWER SUPPLY SW ASSY (B)	
3-1	S38121000	1	モーターケーブルクミ	MOTOR CABLE	
4-2	S38124000	1	ヘンカントランスBクミ	CONVERSION TRANSFORMER (B) ASSY	
5	052501205	4	ナベコパネヒラ5X12	SCREW, PAN (S/P WASHER) M5X12	
6	021500205	4	2シユナツト5	NUT, 2 M5	
7	025050235	4	ヒラザガネチユウ5	WASHER, PLAIN M 5	
<ボックスソウクミC1, C2ヨウ/ FOR POWER SUPPLY BOX ASSY (C1), (C2)>					
<サンソウ 415V, 380V/THREE-PHASE 415V, 380V>					
2-3	S38117000	1	デンゲンSWクミC	POWER SUPPLY SW ASSY (C)	
3-1	S38121000	1	モーターケーブルクミ	MOTOR CABLE	
4-3	S38127000	1	ヘンカントランスCクミ	CONVERSION TRANSFORMER (C) ASSY	
5	052501205	4	ナベコパネヒラ5X12	SCREW, PAN (S/P WASHER) M5X12	
6	021500205	4	2シユナツト5	NUT, 2 M5	
7	025050235	4	ヒラザガネチユウ5	WASHER, PLAIN M 5	
<ボックスソウクミDヨウ/ FOR POWER SUPPLY BOX ASSY (D)>					
<タンソウ 220V, 230V/SINGLE-PHASE 220V, 230V>					
2-4	S38112002	1	デンゲンSWクミA	POWER SUPPLY SW ASSY (A)	
3-1	S38121000	1	モーターケーブルクミ	MOTOR CABLE	
4-1	S38123000	1	ACINコネクタクミ	ACIN CONNECTOR ASSY	
<ボックスソウクミEヨウ/ FOR POWER SUPPLY BOX ASSY (E)>					
<サンソウ 400V/THREE-PHASE 400V>					
2-5	S38120000	1	デンゲンINコードE	POWER SUPPLY IN CORD (E)	
3-2	S38122000	1	モーターケーブルクミ	MOTOR CABLE (E) ASSY	
4-3	S38127000	1	ヘンカントランスCクミ	CONVERSION TRANSFORMER (C) ASSY	
5	052501205	4	ナベコパネヒラ5X12	SCREW, PAN (S/P WASHER) M5X12	
6	021500205	4	2シユナツト5	NUT, 2 M5	
7	025050235	4	ヒラザガネチユウ5	WASHER, PLAIN M 5	
<ボックスソウクミFヨウ/ FOR POWER SUPPLY BOX ASSY (F)>					
<タンソウ 230V/SINGLE-PHASE 230V>					
2-6	S38113000	1	デンゲンINコードA	POWER SUPPLY IN CORD (A)	
3-2	S38122000	1	モーターケーブルクミ	MOTOR CABLE (E) ASSY	
4-1	S38123000	1	ACINコネクタクミ	ACIN CONNECTOR ASSY	

デンゲン/POWER SOURCE	コード/CODE	ヒンメイ	NAME OF PARTS
サンソウ/THREE-PHASE 200V, 220V	S38192009	ボックスソウクミA	POWER SUPPLY BOX ASSY (A)
タンソウ/SINGLE-PHASE 100V	S38193009	ボックスソウクミB	POWER SUPPLY BOX ASSY (B)
サンソウ/THREE-PHASE 415V	S38194009	ボックスソウクミC1	POWER SUPPLY BOX ASSY (C1)
サンソウ/THREE-PHASE 380V	S38210009	ボックスソウクミC2	POWER SUPPLY BOX ASSY (C2)
タンソウ/SINGLE-PHASE 220V, 230V	S38195009	ボックスソウクミD	POWER SUPPLY BOX ASSY (D)
サンソウ/THREE-PHASE 400V	S38196009	ボックスソウクミE	POWER SUPPLY BOX ASSY (E)
タンソウ/SINGLE-PHASE 230V	S38173009	ボックスソウクミF	POWER SUPPLY BOX ASSY (F)

From the library of: Diamond Needle Corp

118-Z30-502

N2. コントロールボックス関係 / Control box mechanism / Schaltkasten / Mécanisme du boîtier de contrôle / Mecanismo de la caja de controles

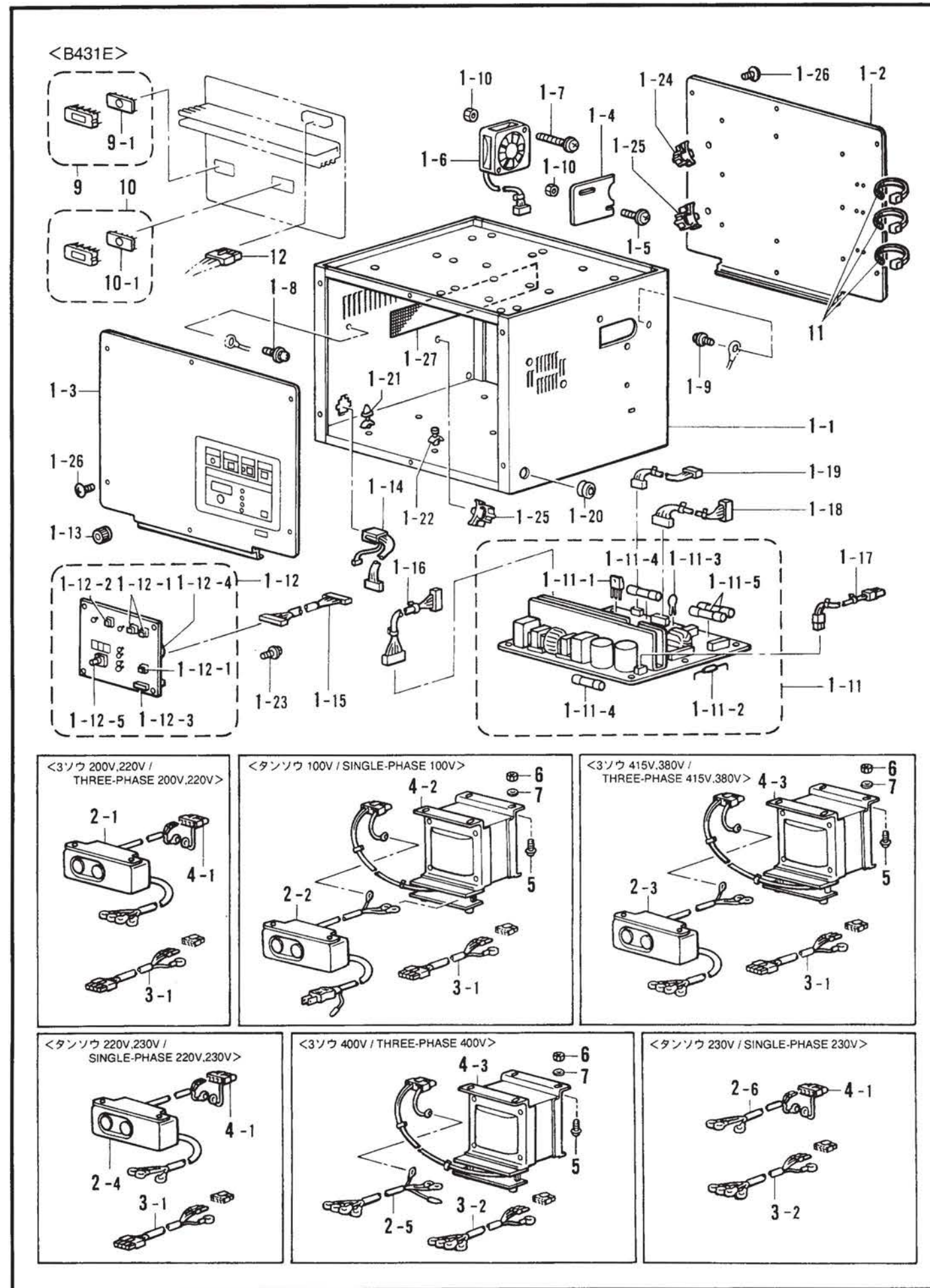

118-Z30-502

N2. コントロールボックス関係 / Control box mechanism / Schaltkasten / Mécanisme du boîtier de contrôle / Mecanismo de la caja de controles

REF.NO.	CODE	Q'TY	ヒンメイ	NAME OF PARTS	RM
<B431E>					
1	S41080009	1	ボックス431クミ	BOX 431 ASSY	
1-1	S38088009	1	デンゲンボックス	POWER SUPPLY BOX	
1-2	S38089009	1	メインキバントリツケイタ	MAIN P.C. BOARD MOUNTING PLATE	
1-3	S38090009	1	パネルトリツケイタクミ	PANEL MOUNTING ASSY	
1-4	S38093000	1	コードオサエイタ	CORD PRESSER PLATE	
1-5	0A5401206	2	+ナベザクミ4X12DB	SCREW, PAN (WASHER) M4X35DB	
1-6	S38094000	1	DCファンモータクミ	DC FAN MOTOR ASSY	
1-7	0A5403506	2	+ナベザクミ4X35DB	SCREW, PAN (WASHER) M4X35DB	
1-8	0A5400806	1	+ナベザクミ4X8DB	SCREW, PAN (WASHER) M4X8DB	
1-9	0A5401206	1	+ナベザクミ4X12DB	SCREW, PAN (WASHER) M4X35DB	
1-10	021400206	4	2シユナツト4	NUT, 2 M4	
1-11	S38095001	1	デンゲンキバンクミ	POWER SUPPLY CIRCUIT BOARD ASSY	
1-11-1	S38200000	2	MOSFET2SK1938	MOSFET2SK1938	
1-11-2	232384001	1	SアブソバDSA362MA	SURGE ABSORBER	
1-11-3	S38201000	2	バリスタV14D471	VARISTOR	
1-11-4	S08030000	2	Gヒューズ5AFB	G FUSE (5AFB)	
1-11-5	157219000	2	カンヒューズ5A-D	FUSE 5A-D	
1-12	S38102001	1	パネルキバンクミ	PANEL CIRCUIT BOARD ASSY	
1-12-1	S30260002	3	SWDP1-100	SWDP1-100	
1-12-2	S30260003	1	SWDP1-100	SWDP1-100	
1-12-3	U16693000	1	DIPスイッチDSS808-1	DIP SWITCH:DSS808-1	
1-12-4	S30280000	1	ブザーPKB24SPC36	BUZZER PKB24SPC36	
1-12-5	S38104000	1	エンコーダEVQVEMF01	ENCODER EVQVEMF01	
1-13	S02907000	1	ツマミ	DIAL	
1-14	S41102000	1	フットSWコード431クミ	FOOT SW CORD 431 ASSY	
1-15	S38106000	1	パネルケーブルクミ	PANEL CABLE ASSY	
1-16	S38107000	1	セイギヨデンゲンコード	CONTROL POWER SUPPLY CORD	
1-17	S38108000	1	モータデンゲンコード	MOTOR POWER SUPPLY CORD	
1-18	S38109000	1	ゲートデンゲンコード	GATE POWER SUPPLY CORD	
1-19	S38110000	1	PERコード	PER CORD	
1-20	S11949000	2	ゴムブツシュ	RUBBER BUSH	
1-21	S00554000	16	サポート6NS	SUPPORT 6NS	
1-22	S38111000	1	サポート6S	SUPPORT 6S	
1-23	0A4300605	4	+ナベザクミ3X6DA	SCREW, PAN (WASHER) M3X6DA	
1-24	150357001	1	コードランプ13	CORD CLAMP (13-L)	
1-25	S09141000	2	コードランプ16L	CORD CLAMP (16-L)	
1-26	008400604	12	+トラスコ4X6	SCREW, TRUSS M4X6	
1-27	S38116000	1	ボウジンアミ	FRAGMENT PROTECTOR NET	
9	S41101000	1	PROMセイギヨ431クミ	PROM CONTROL 431 ASSY	
9-1	S38143000	1	CMOSLSI27C512	CMOSLSI27C512	
10	S38131000	1	PROMモータクミ	PROM MOTOR ASSY	
10-1	S38143000	1	CMOSLSI27C512	CMOSLSI27C512	
11	228475000	8	ケツソクバンド1.9X80	BINDER	
12	S16568000	1	コネクタ3191-03R1	CONNECTOR (3191-03R1)	

From the library of: Diamond Needle Corp

118-Z30-502

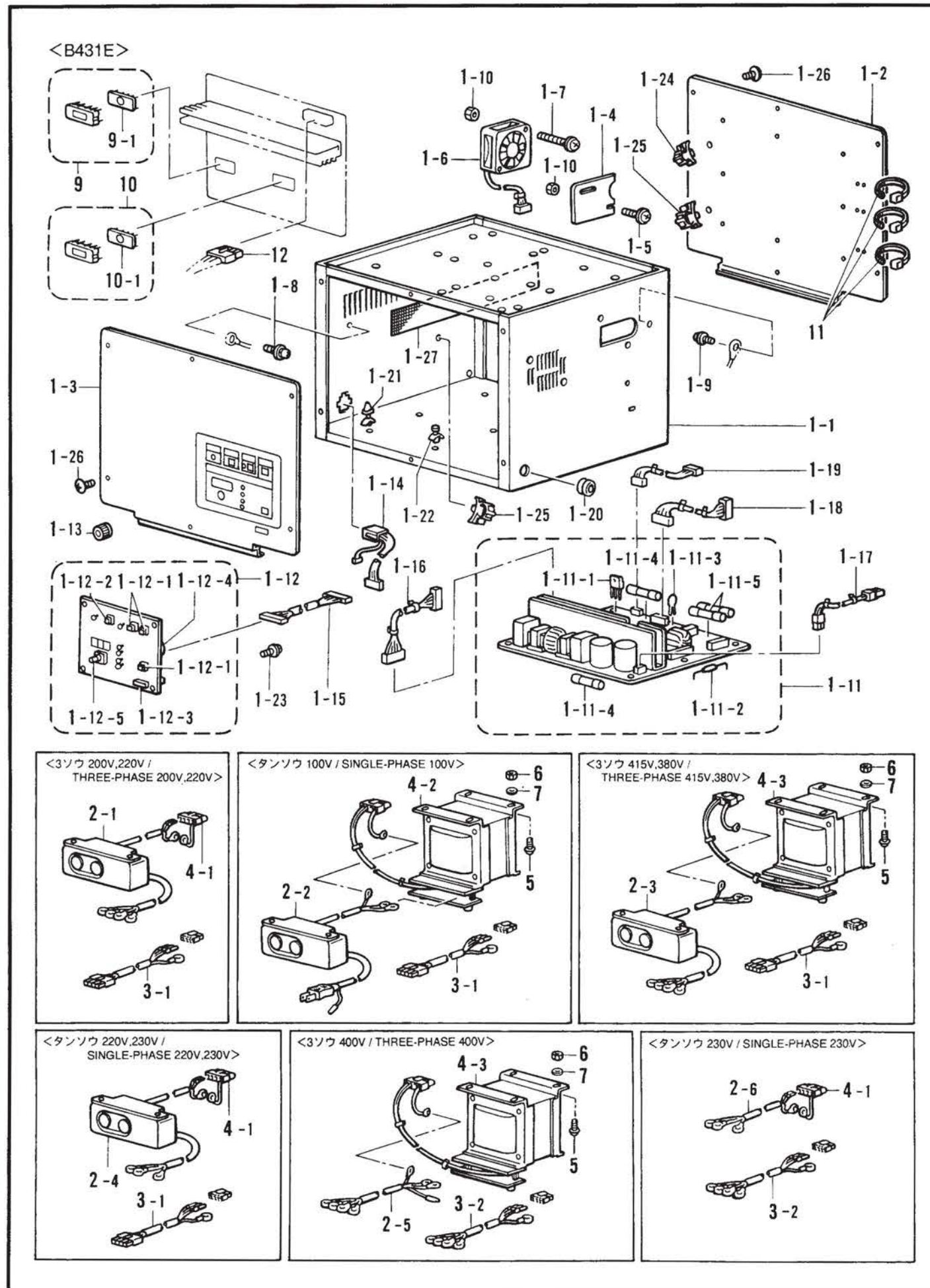

REF.NO.	CODE	Q'TY	ヒンメイ	NAME OF PARTS	RM
<B431E>					
<ボックスソウクミAヨウ/ FOR POWER SUPPLY BOX ASSY (A)>					
<サンソウ 200V, 220V / THREE-PHASE 200V, 220V>					
2-1	S41099001	1	デンゲンSW 431A クミ	POWER SUPPLY SW (431A) ASSY	
3-1	S38121000	1	モーターケーブルクミ	MOTOR CABLE	
4-1	S38123000	1	ACINコネクタクミ	ACIN CONNECTOR ASSY	
<ボックスソウクミBヨウ/ FOR POWER SUPPLY BOX ASSY (B)>					
<タンソウ 100V / SINGLE-PHASE 100V>					
2-2	S38114000	1	デンゲンSWクミB	POWER SUPPLY SW ASSY (B)	
3-1	S38121000	1	モーターケーブルクミ	MOTOR CABLE	
4-2	S38124000	1	ヘンカントランスBクミ	CONVERSION TRANSFORMER (B) ASSY	
5	052501205	4	ナベコパネヒラ5X12	SCREW, PAN (S/P WASHER) M5X12	
6	021500205	4	2シユナツト5	NUT, 2 M5	
7	025050235	4	ヒラザガネチユウ5	WASHER, PLAIN M 5	
<ボックスソウクミC1,C2ヨウ/ FOR POWER SUPPLY BOX ASSY (C1), (C2)>					
<サンソウ 415V, 380V / THREE-PHASE 415V, 380V>					
2-3	S38117000	1	デンゲンSWクミC	POWER SUPPLY SW ASSY (C)	
3-1	S38121000	1	モーターケーブルクミ	MOTOR CABLE	
4-3	S38127000	1	ヘンカントランスCクミ	CONVERSION TRANSFORMER (C) ASSY	
5	052501205	4	ナベコパネヒラ5X12	SCREW, PAN (S/P WASHER) M5X12	
6	021500205	4	2シユナツト5	NUT, 2 M5	
7	025050235	4	ヒラザガネチユウ5	WASHER, PLAIN M 5	
<ボックスソウクミDヨウ/ FOR POWER SUPPLY BOX ASSY (D)>					
<タンソウ 220V, 230V / SINGLE-PHASE 220V, 230V>					
2-4	S41099002	1	デンゲンSW 431A クミ	POWER SUPPLY SW (431A) ASSY	
3-1	S38121000	1	モーターケーブルクミ	MOTOR CABLE	
4-1	S38123000	1	ACINコネクタクミ	ACIN CONNECTOR ASSY	
<ボックスソウクミEヨウ/ FOR POWER SUPPLY BOX ASSY (E)>					
<サンソウ 400V / THREE-PHASE 400V>					
2-5	S38120000	1	デンゲンINコードE	POWER SUPPLY IN CORD (E)	
3-2	S38122000	1	モーターケーブルEクミ	MOTOR CABLE (E) ASSY	
4-3	S38127000	1	ヘンカントランスCクミ	CONVERSION TRANSFORMER (C) ASSY	
5	052501205	4	ナベコパネヒラ5X12	SCREW, PAN (S/P WASHER) M5X12	
6	021500205	4	2シユナツト5	NUT, 2 M5	
7	025050235	4	ヒラザガネチユウ5	WASHER, PLAIN M 5	
<ボックスソウクミFヨウ/ FOR POWER SUPPLY BOX ASSY (F)>					
<タンソウ 230V / SINGLE-PHASE 230V>					
2-6	S41100000	1	デンゲンIN 431A	POWER SUPPLY IN CORD (431A)	
3-2	S38122000	1	モーターケーブルEクミ	MOTOR CABLE (E) ASSY	
4-1	S38123000	1	ACINコネクタクミ	ACIN CONNECTOR ASSY	

デンゲン/POWER SOURCE	コード/CODE	ヒンメイ	NAME OF PARTS
サンソウ/THREE-PHASE 200V, 220V	S41081009	ボックスソウクミ 431A	POWER SUPPLY BOX ASSY (431A)
タンソウ/SINGLE-PHASE 100V	S41082009	ボックスソウクミ 431B	POWER SUPPLY BOX ASSY (431B)
サンソウ/THREE-PHASE 415V	S41083009	ボックスソウクミ 431C1	POWER SUPPLY BOX ASSY (431C1)
サンソウ/THREE-PHASE 380V	S41084009	ボックスソウクミ 431C2	POWER SUPPLY BOX ASSY (431C2)
タンソウ/SINGLE-PHASE 220V, 230V	S41085009	ボックスソウクミ 431D	POWER SUPPLY BOX ASSY (431D)
サンソウ/THREE-PHASE 400V	S41086009	ボックスソウクミ 431E	POWER SUPPLY BOX ASSY (431E)
タンソウ/SINGLE-PHASE 230V	S41087009	ボックスソウクミ 431F	POWER SUPPLY BOX ASSY (431F)

From the library of: Diamond Needle Corp

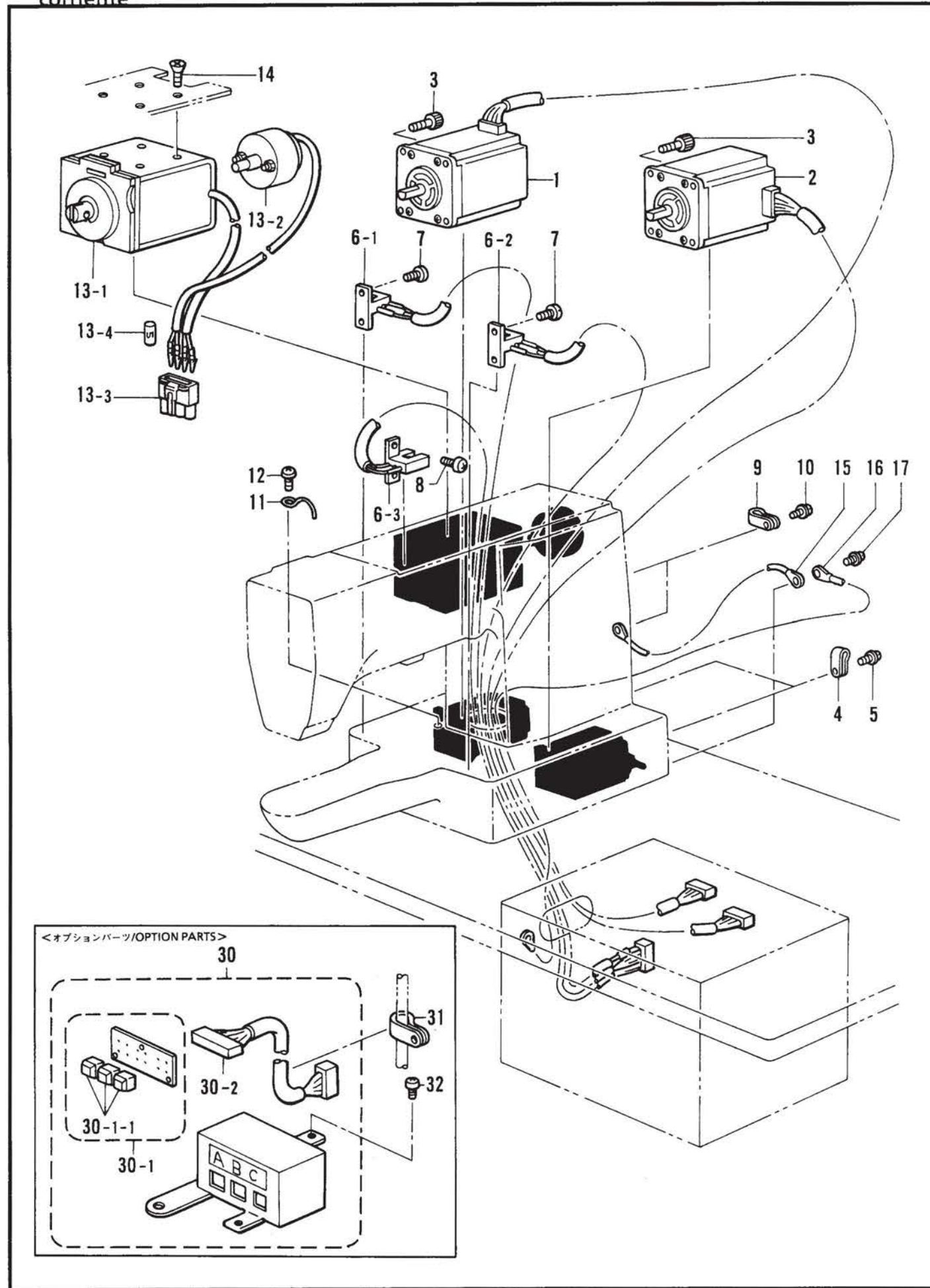

118-Z30-515

REF.NO.	CODE	Q'TY	ヒンメイ	NAME OF PARTS	RM
1	S38134000	1	ハルスモータXクミ	X-PULSE MOTOR ASSY	
2	S38136000	1	ハルスモータYクミ	Y-PULSE MOTOR ASSY	
3	018401222	8	アナボルト4X12	BOLT, SOCKET M4X12	
4	552907000	2	コードホルダ#10	CORD HOLDER (10N)	
5	052400806	2	ナベコバネヒラ4X8	SCREW, PAN (S/P WASHER) M4X8	
7	062300412	4	ナベコ3X4	SCREW, PAN M3X4	
8	062300412	2	ナベコ3X4	SCREW, PAN M3X4	
9	525907000	2	コードホルダ#9	CORD HOLDER (9N)	
10	0A5401006	2	+ナベザクミ4X10DB	SCREW, PAN (WASHER) M4X10DB	
11	152969001	1	コードササエカネ	CORD SUPPORT	
12	062670512	1	ナベコ357-40X5	SCREW, PAN SM3.57-40X5	
13-1	S38142000	1	オサエソレノイドクミ	PRESSER SOLENOID ASSY	
13-2	S38144000	1	イトキリソレノイドクミ	THREAD TRIMMING SOLENOID ASSY	
13-3	S38146000	1	コネクタ3191-04R	CONNECTOR 3191-04R	
13-4	S38147000	1	マークチューブ5	MARK TUBE 5	
14	004501003	4	+サラコ5X10	SCREW, FLAT M5X10	
15	S38148000	1	アースセン1	GROUND WIRE 1	
16	S38145000	1	アースセン2	GROUND WIRE 2	
17	052400806	1	ナベコバネヒラ4X8	SCREW, PAN (S/P WASHER) M4X8	
<オプションパーツ/OPTION PARTS>					
30	S38048009	1	OPボックスクミ	OP BOX ASSY	
30-1	S38051000	1	OPキバンクミ	OP CIRCUIT BOARD ASSY	
30-1-1	S38056000	3	SWJB-15LMP2	SWJB-15LMP2	
30-2	S38053000	1	OPボックスハーネス	OP BOX HARNESS	
31	S00480000	2	コードホルダ#5	CORD HOLDER (5N)	
32	062681012	3	ナベコ437-40X10	SCREW, PAN SM4.37-40X10	
<B430E,B433E>					
6	S38137000	1	トウブセンサクミ	HEAD SENSOR ASSY	
6-1	S38138000	1	ゲンテンセンサXハーネス	HOME POSITION SENSOR X HARNESS	
6-2	S38139000	1	ゲンテンセンサYハーネス	HOME POSITION SENSOR Y HARNESS	
6-3	S38140000	1	オサエセンサハーネス	SEWING CLAMP SENSOR HARNESS	
<B431E>					
6	S41177000	1	トウブセンサ431クミ	HEAD SENSOR 431 ASSY	
6-1	S41178000	1	ゲンテンセンサX431クミ	HOME POSITION SENSOR X 431 ASSY	
6-2	S41179000	1	ゲンテンセンサY431クミ	HOME POSITION SENSOR Y 431 ASSY	
6-3	S41180000	1	オサエセンサハーネス431クミ	SEWING CLAMP SENSOR HARNESS 431 ASSY	

From the library of: Diamond Needle Corp

118-Z30-515

Q. プリント基板関係 / Printed circuit board mechanism / Leiterplatten / Circuits imprimés /
Tableros de circuitos impresos

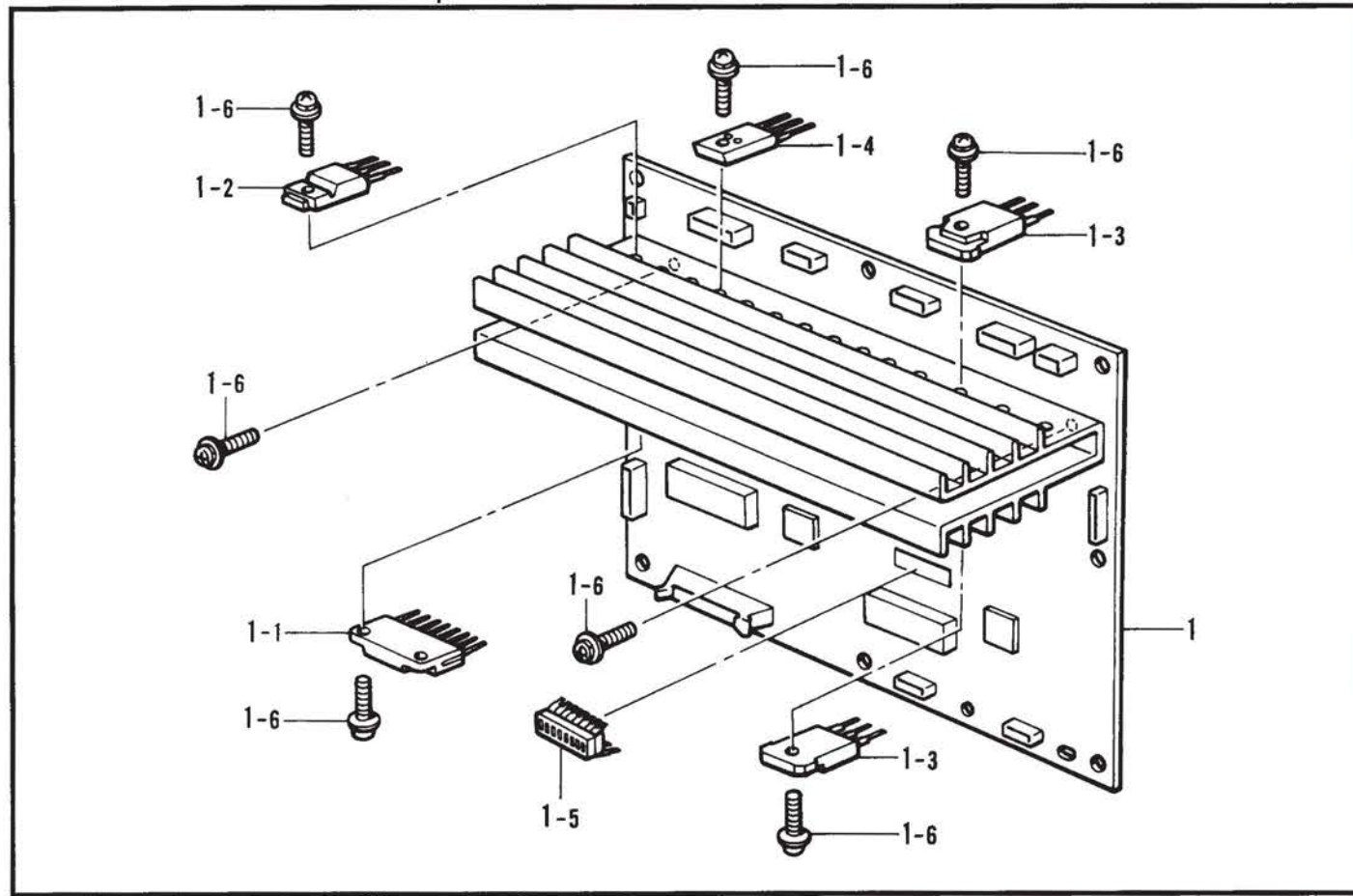

118-Z30-518

R. 動力台関係 / Power table / Motorgestell / Mécanisme du plateau de la machine / Mecanismo
de la mesa de la máquina

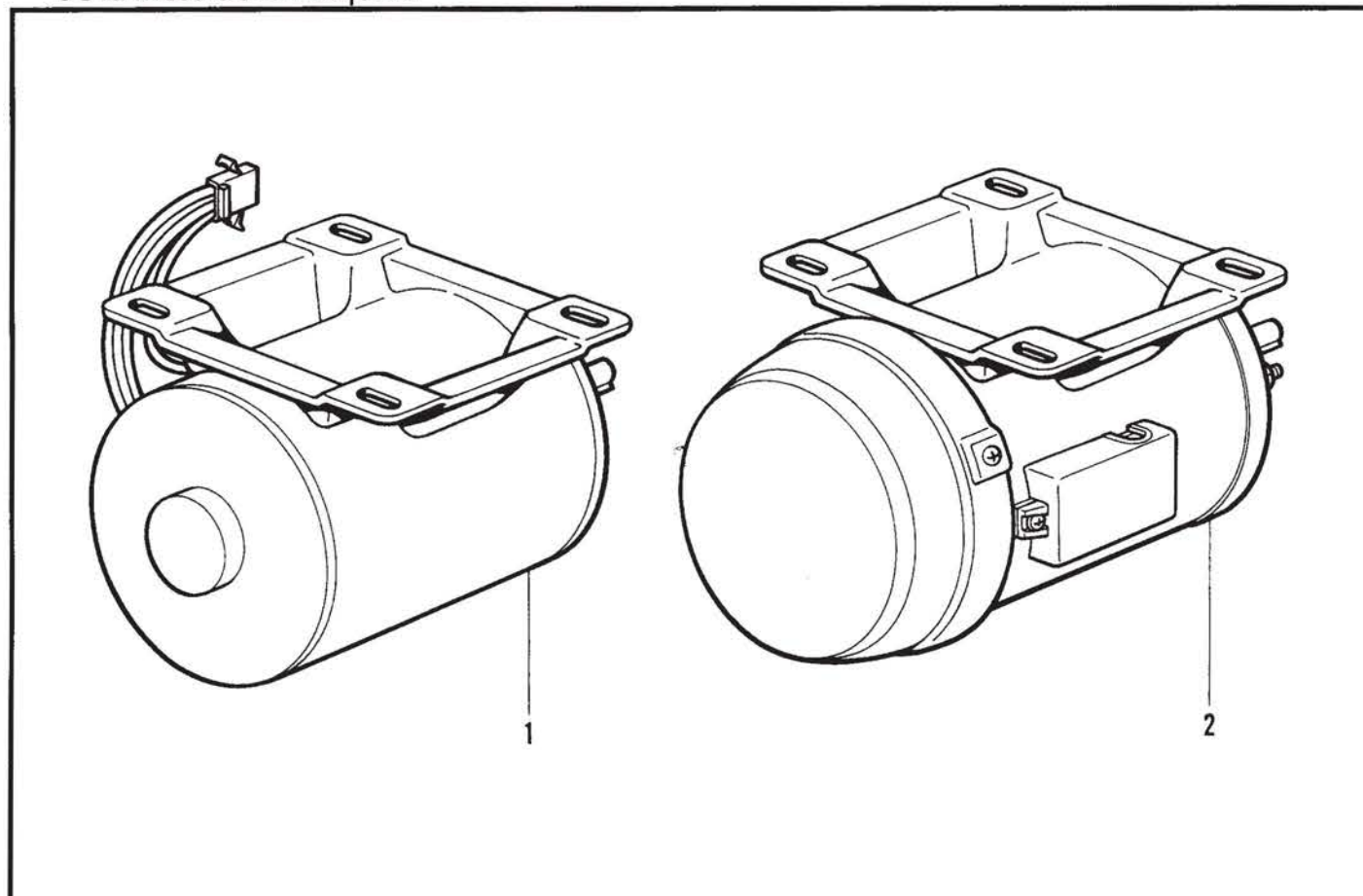

118-Z30-652

Q. プリント基板関係 / Printed circuit board mechanism / Leiterplatten / Circuits imprimés /
Tableros de circuitos impresos

REF.NO.	CODE	Q'TY	ヒンメイ	NAME OF PARTS	RM
1	S38151001	1	メイン基板	MAIN CIRCUIT BOARD ASSY	
1-1	S38154000	4	BIPICSLA4390	BIPICSLA4390	
1-2	S38155000	3	MOSFET2SK1306	MOSFET2SK1306	
1-3	S38164000	6	MOSFET2SK1937	MOSFET2SK1937	
1-4	S33849000	8	FRDアレイ D8LD20U	FRD ARRAY D8LD20U	
1-5	U32744000	1	DIPSWDSS708	DIP SWITCH:DSS708	
1-6	0A4301005	27	+ナベザクミ 3X10DA	SCREW, PAN (S/P WASHER) M3X10	

118-Z30-518

R. 動力台関係 / Power table / Motorgestell / Mécanisme du plateau de la machine / Mecanismo
de la mesa de la máquina

REF.NO.	CODE	Q'TY	ヒンメイ	NAME OF PARTS	RM
1	S38191000	1	モータ EMDBH0.4KWクミ	MOTOR EMDBH 0.4KW ASSY	
2	S10405000	1	ゼンハイ3ソウモータ	TOTALLY ENCLOSED 3-PHASE MOTOR	

118-Z30-652

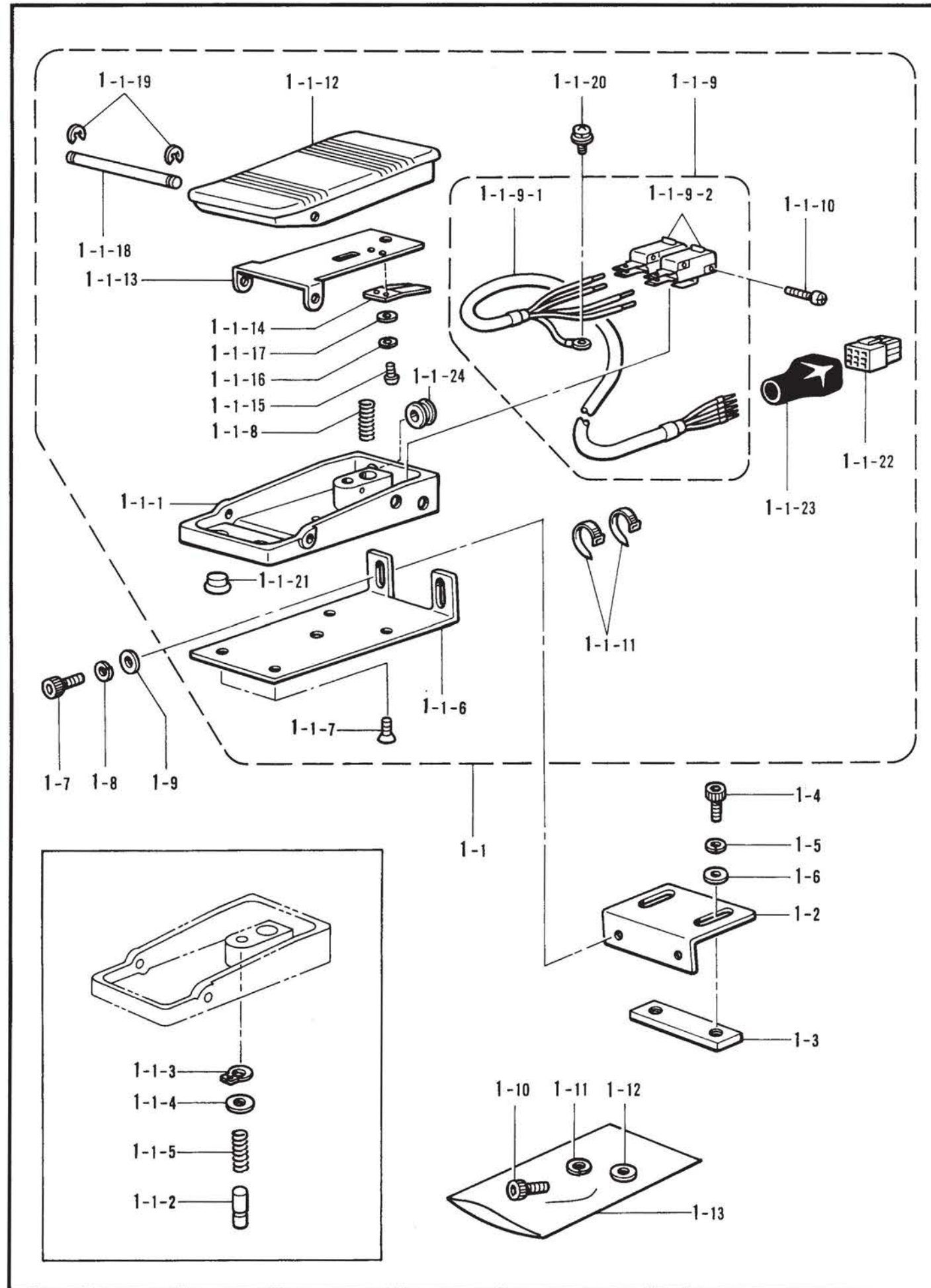

118-Z30-651

REF.NO.	CODE	Q'TY	品名	NAME OF PARTS	RM
1	S38057101	1	2ダンフットSWセット	2-STAGE FOOT SW SET	
1-1	S38165101	1	2ダンフットSWクミ	2-STAGE FOOT SW ASSY	
1-1-1	S38166000	1	フットペダルダイ	FOOT PEDAL STAND	
1-1-2	S38167001	1	2ダンSWピン	2-STAGE SW PIN	
1-1-3	048060142	1	トメワジクヨウ C6	RETAINING RING, C6	
1-1-4	025060236	1	ヒラザガネチユウ6	WASHER, PLAIN M 6	
1-1-5	S38168001	1	アツシユクバネ	SPRING	
1-1-6	S38169101	1	フットSWシジイタB	FOOT SW SUPPORT PLATE (B)	
1-1-7	004400803	2	+サラネジ4X8	SCREW, FLAT M4X8	
1-1-8	S38170001	1	フットペダルバネ	FOOT PEDAL SPRING	
1-1-9	S38171000	1	フットSWハーネスクミ	FOOT SW HARNESS ASSY	
1-1-9-1	S38172000	1	フットSWハーネス	FOOT SW HARNESS	
1-1-9-2	S36260000	2	スイッチVXピンボタン	SWITCH (VX) PIN BUTTON	
1-1-10	062302506	2	ナベコ3X25	SCREW, PAN M3X25	
1-1-11	228475000	2	ケツソクバンド1.9X80	BINDER	
1-1-12	S38174000	1	フットペダル	FOOT PEDAL	
1-1-13	S38175001	1	ペダルホゴイタ	PEDAL PROTECTION PLATE	
1-1-14	S38176001	1	スイッチオサエバネ	SWITCH SPRING	
1-1-15	002300403	2	+ナベコ3X4	SCREW, PAN M3X4	
1-1-16	028030246	2	バネザガネ2-3	WASHER, SPRING 2-3	
1-1-17	025030236	2	ヒラザガネチユウ3	WASHER, PLAIN M 3	
1-1-18	S38177001	1	フットペダルジク	FOOT PEDAL SHAFT	
1-1-19	048050346	2	トメワE5	RETAINING RING, E5	
1-1-20	052400606	1	ナベコバネヒラ4X6	SCREW, PAN (S/P WASHER) M4X6	
1-1-21	117936001	4	メクラセン	OIL CAP	
1-1-22	S38180000	1	コネクタ172169-1	CONNECTOR 172169-1	
1-1-23	S36682000	1	コネクタキャップ	CONNECTOR CAP	
1-1-24	S38059000	2	グロメットNG79F	GROMMET NG79F	
1-2	S38178101	1	フットSWシジイタA	FOOT SW SUPPORT PLATE (A)	
1-3	S38179101	1	フットSWシジイタC	FOOT SW SUPPORT PLATE (C)	
1-4	018082536	2	アナボルト8X25	BOLT, SOCKET M8X25	
1-5	028080246	2	バネザガネ2-8	WASHER, SPRING 2-8	
1-6	025080236	2	ヒラザガネチユウ8	WASHER, PLAIN M 8	
1-7	018501036	2	アナボルト5X10	BOLT, SOCKET M5X10	
1-8	028050246	2	バネザガネ2-5	WASHER, SPRING 2-5	
1-9	025050236	2	ヒラザガネチユウ5	WASHER, PLAIN M 5	
1-10	018401236	2	アナボルト4X12	BOLT, SOCKET M4X12	
1-11	028040246	2	バネザガネ2-4	WASHER, SPRING 2-4	
1-12	025040236	2	ヒラザガネチユウ4	WASHER, PLAIN M 4	
1-13	144749001	1	ポリフクロ	POLYETHYLENE BAG	

From the library of: Diamond Needle Corp

118-Z30-651

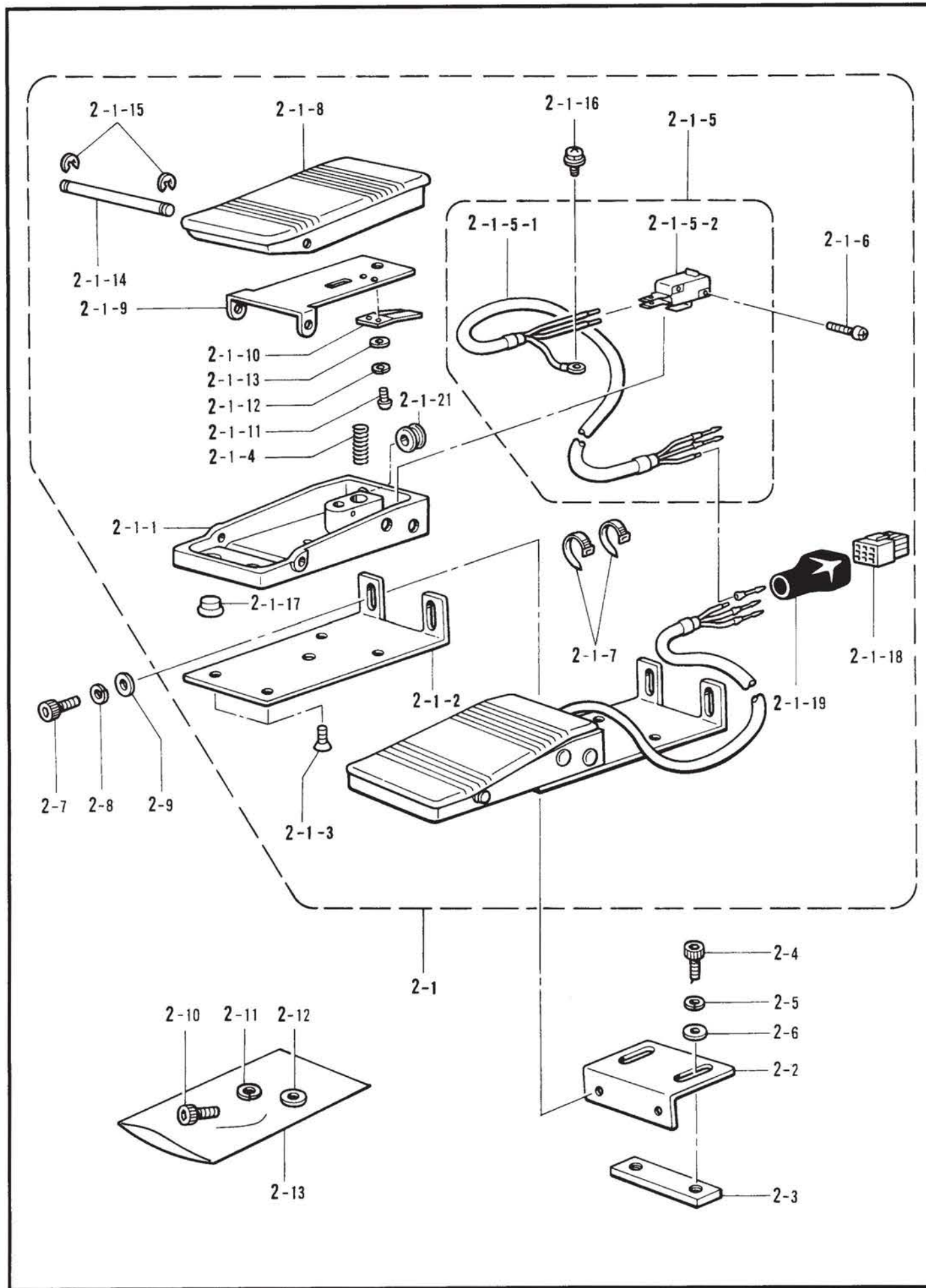

118-Z30-651

REF.NO.	CODE	Q'TY	ヒンメイ	NAME OF PARTS	RM
2	S38058101	1	2レンペダルセット	2-PEDAL FOOT SW SET	
2-1	S38027101	1	2レンペダルクミ	2-PEDAL FOOT SW ASSY	
2-1-1	S38166000	2	フットペダルダイ	FOOT PEDAL STAND	
2-1-2	S38169101	2	フットSWシジイタB	FOOT SW SUPPORT PLATE (B)	
2-1-3	004400803	4	+サラネジ4X8	SCREW, FLAT M4X8	
2-1-4	S38170001	2	フットペダルバネ	FOOT PEDAL SPRING	
2-1-5	S38029000	2	2レンフットSWハーネスクミ	2-PEDAL FOOT SW HARNESS ASSY	
2-1-5-1	S38030000	2	2レンフットSWハーネス	2-PEDAL FOOT SW HARNESS	
2-1-5-2	S36260000	2	スイッチVXピンボタン	SWITCH (VX) PIN BUTTON	
2-1-6	062301205	4	ナベコ3X12	SCREW, PAN M3X12	
2-1-7	228475000	10	ケツソクバンド1.9X80	BINDER	
2-1-8	S38174000	2	フットペダル	FOOT PEDAL	
2-1-9	S38175001	2	ペダルホゴイタ	PEDAL PROTECTION PLATE	
2-1-10	S38176001	2	スイッチオサエバネ	SWITCH SPRING	
2-1-11	002300403	4	+ナベコ3X4	SCREW, PAN M3X4	
2-1-12	028030246	4	バネザガネ2-3	WASHER, SPRING 2-3	
2-1-13	025030236	4	ヒラザガネチユウ3	WASHER, PLAIN M 3	
2-1-14	S38177001	2	フットペダルジク	FOOT PEDAL SHAFT	
2-1-15	048050346	4	トメワE5	RETAINING RING, E5	
2-1-16	052400606	2	ナベコバネヒラ4X6	SCREW, PAN (S/P WASHER) M4X6	
2-1-17	117936001	8	メクラセン	OIL CAP	
2-1-18	S38180000	1	コネクタ172169-1	CONNECTOR 172169-1	
2-1-19	S36682000	1	コネクタキャップ	CONNECTOR CAP	
2-1-21	S38059000	2	グロメットNG79F	GROMMET NG79F	
2-2	S38178101	2	フットSWシジイタA	FOOT SW SUPPORT PLATE (A)	
2-3	S38179101	2	フットSWシジイタC	FOOT SW SUPPORT PLATE (C)	
2-4	018082536	4	アナボルト8X25	BOLT, SOCKET M8X25	
2-5	028080246	4	バネザガネ2-8	WASHER, SPRING 2-8	
2-6	025080236	4	ヒラザガネチユウ8	WASHER, PLAIN M 8	
2-7	018501036	4	アナボルト5X10	BOLT, SOCKET M5X10	
2-8	028050246	4	バネザガネ2-5	WASHER, SPRING 2-5	
2-9	025050236	4	ヒラザガネチユウ5	WASHER, PLAIN M 5	
2-10	018401236	4	アナボルト4X12	BOLT, SOCKET M4X12	
2-11	028040246	4	バネザガネ2-4	WASHER, SPRING 2-4	
2-12	025040236	4	ヒラザガネチユウ4	WASHER, PLAIN M 4	
2-13	144749001	1	ポリフクロ	POLYETHYLENE BAG	

From the library of: Diamond Needle Corp

118-Z30-651

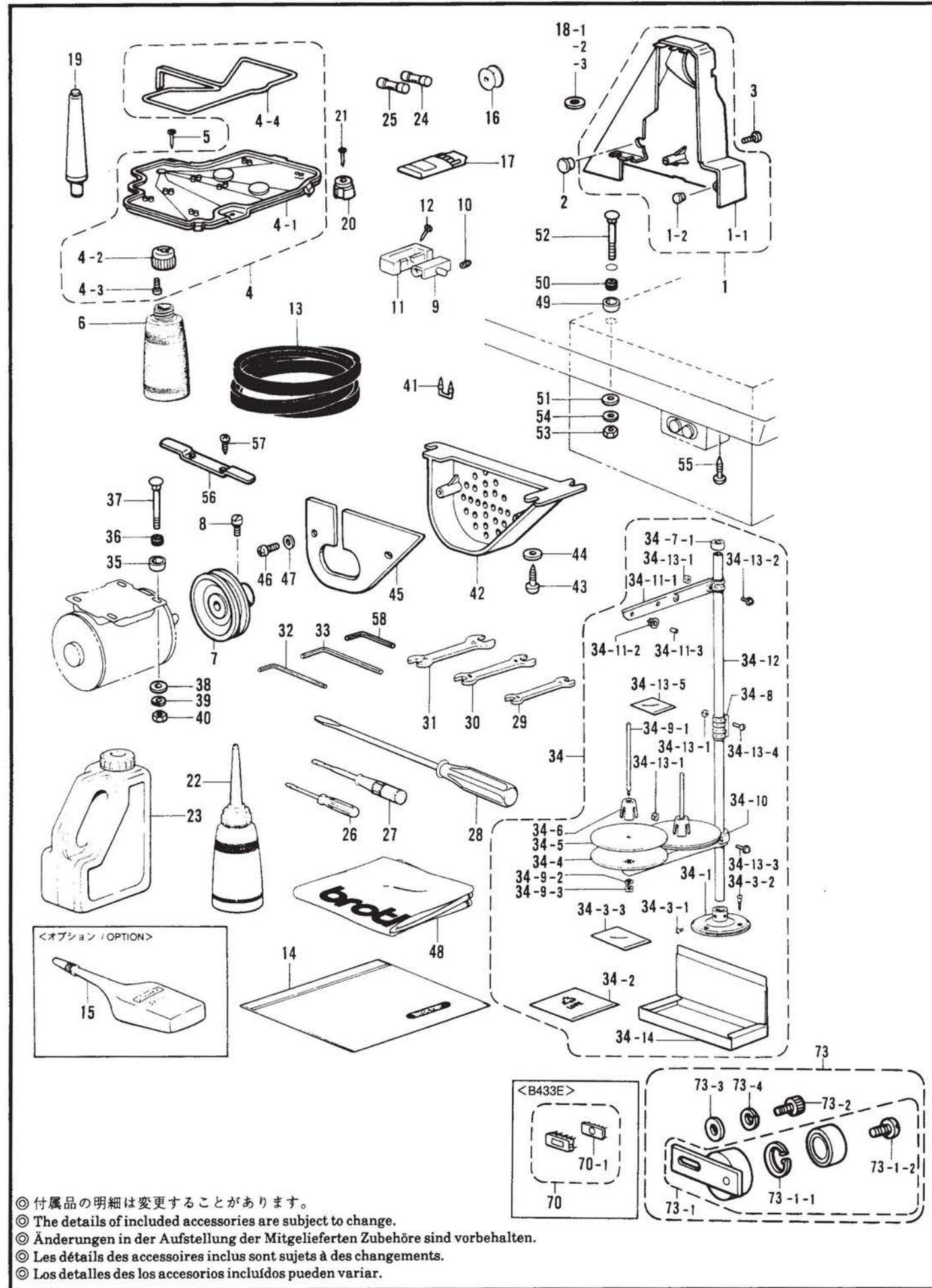

REF.NO.	CODE	Q'TY	品名	NAME OF PARTS	RM
1	S38037009	1	ベルトカバークミ	BELT COVER ASSY	
1-1	S38038009	1	ベルトカバー	BELT COVER	
1-2	104450109	1	メクラセン	OIL CAP	
2	117934009	1	メクラセン	OIL CAP	
3	062401006	1	ナベコ4X10	SCREW, PAN M4X10	
4	S38039009	1	オイルパンクミ	OIL PAN ASSY	
4-1	S38040009	1	オイルパン	OIL PAN	
4-2	154467001	1	ハイユキヤツブ	DUST OILER	
4-3	037301215	2	Vナベタツピン3X12	TAPPING SCREW, PAN V M3X12	
4-4	S18093100	1	クミヒモ4X4	WICK 4X4	
5	109714000	5	クギ	NAIL	
6	114486002	1	ポリオイラータイ	OILER	
7	S38041000	1	モータープリー	MOTOR PULLEY	
8	105073001	1	アタマツキトメネジ5.95	SET SCREW, SOCKET M5.95	
9	143882001	2	トウブヒンジ	HEAD HINGE	
10	014760622	2	アノメネジ5.95	SET SCREW, SOCKET (CP) SM5.95	
11	143910009	2	トウブヒンジウケゴム	RUBBER CUSHION	
12	109714000	4	クギ	NAIL	
13	S40417147	1	ローエッジVベルトM	BELT, VM	
14	122991001	1	フソクヒンポリフクロ	ACCESSORY BAG	
16	159613001	3	ボビン	BOBBIN	
17	※	1	ミシンハリクミ	NEEDLE ASSY	
18-1	S10208001	1	イドウハカンザ T=0.4	WASHER T=0.4	
18-2	S10208002	1	イドウハカンザ T=0.5	WASHER T=0.5	
18-3	S10208003	1	イドウハカンザ T=0.6	WASHER T=0.6	
19	S38045009	1	マクラクミ	HEAD REST ASSY	
20	S38043009	2	クッション	CUSHION	
21	109714000	2	クギ	NAIL	
22	114483002	1	ポリオイラークミ	OILER ASSY	
23	154702101	1	オイルタンク	OIL TANK	
24	S08030000	1	Gヒューズ5AFB	G FUSE (5AFB)	
25	157219000	1	カンヒューズ5A-D	FUSE 5A-D	
26	142443001	1	ネジマワシ1.9X52	SCREW DRIVER 1.9X52	
27	118837001	1	ネジマワシ3.4X70	SCREW DRIVER 3.4X70	
28	101572101	1	ネジマワシ5.5X190	SCREW DRIVER 5.5X190	
29	107779001	1	スパナ6X7	SPANNER 6X7	
30	100887001	1	スパナ8X9	SPANNER 8X9	
31	107780001	1	スパナ10X12	SPANNER 10X12	
32	142721001	1	6カクボウスパナ3	HEXAGONAL WRENCH 3	
33	118064001	1	6カクボウスパナ4	HEXAGONAL WRENCH 4	
34	S02761209	1	イトタテダイクミ2	COTTON STAND ASSY (2)	
34-1	150189109	1	ブラケット	COTTON STAND BASE	
34-2	S02791001	1	PEフクロ150X150	PE. BAG, 150X150	
34-3	S02773001	1	ブラケットネジセット	COTTON STAND BRACKET SCREW SET	
34-3-1	062060806	2	ナベコ6X8	SCREW, PAN M6X8	
34-3-2	031452206	3	マルモク45X22	WOOD SCREW, ROUND M4.5X22	
34-3-3	S02774000	1	ポリフクロA	PE. BAG, A	
34-4	150180001	2	ウケザラ	SPOOL STAND BASE	
34-5	150182000	2	スプールマット	SPOOL MAT	
34-6	126863001	2	スプールクッション	SPOOL CUSHION	
34-7	S40639001	1	コラムパイプキヤツブツキ	COLUMN PIPE WITH CAP	
34-7-1	150174000	1	コラムキヤツブ	COLUMN CAP	
34-8	150173003	1	コラムジョイント	COLUMN JOINT	
34-9	S21798001	2	スプールネジセット	SPOOL SCREW SET	
34-9-1	150179002	2	スプールジクB	SPOOL SHAFT, B	
34-9-2	028050246	2	バネザガネ2-5	WASHER, SPRING 2-5	
34-9-3	021500106	2	1シユナツト5	NUT, 1 M5	
34-10	S02778002	1	スプールホルダー2	SPOOL HOLDER 2	
34-11	S02786002	1	スレツドハンガークミ2	THREAD HANGER ASSY 2	

From the library of: Diamond Needle Corp

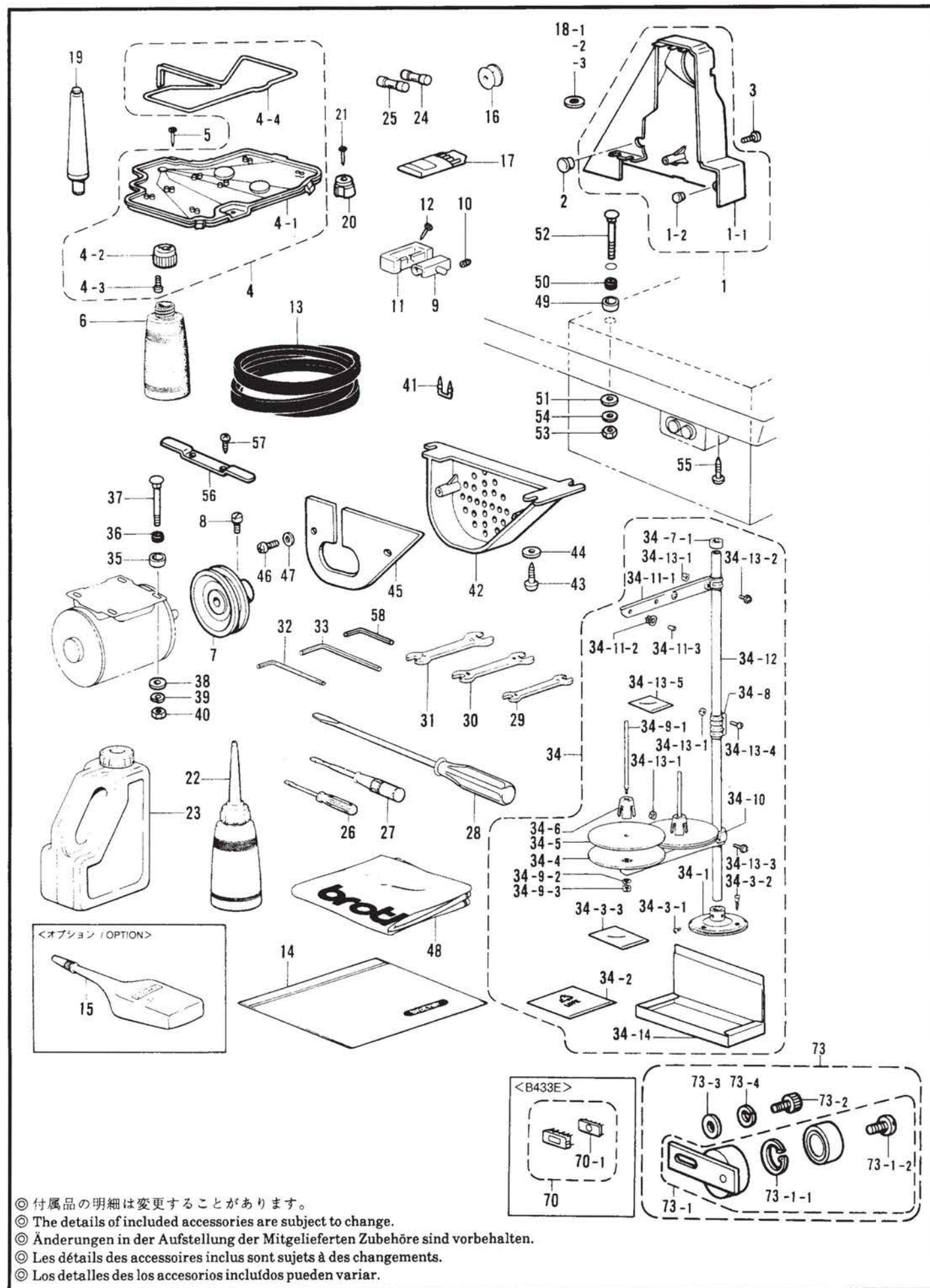

◎ 付属品の明細は変更することがあります。
 ◎ The details of included accessories are subject to change.
 ◎ Änderungen in der Aufstellung der Mitgelieferten Zubehöre sind vorbehalten.
 ◎ Les détails des accessoires inclus sont sujets à des changements.
 ◎ Los detalles de los accesorios incluidos pueden variar.

REF.NO.	CODE	Q'TY	ヒンメイ	NAME OF PARTS	RM
34-11-1	S02787002	1	スレッドハンガー-2	THREAD HANGER, 2	
34-11-2	150183000	2	イトカケハンガーダイ	THREAD HANGER BASE	
34-11-3	142990001	2	スレッドブツシュ	THREAD BUSH	
34-12	150172003	1	コラムパイプ	COLUMN PIPE	
34-13	S40641001	1	スプールジクネジセットA	SPOOL SCREW SET (A)	
34-13-1	021500106	4	1シユナツト5	NUT, 1 M5	
34-13-2	S37038001	1	ナベコヒラザ5X14	SCREW, PAN (P WASHER) M5X14	
34-13-3	S37038001	1	ナベコヒラザ5X14	SCREW, PAN (P WASHER) M5X14	
34-13-4	062501406	2	ナベコ5X14	SCREW, PAN M5X14	
34-13-5	S30302000	1	ポリフクロS	PE. BAG, 70X70	
34-14	S02816000	1	ソトハコ	CARTON	
35	146256001	4	クツシヨソカナダ	CUSHION COLLAR	
36	146255000	4	クツシヨソ	CUSHION	
37	133740006	4	カクネボルト6X70	BOLT, M6X70	
38	025060336	4	ヒラザガネダイ6	WASHER, PLAIN L 6	
39	028060246	4	バネザガネ2-6	WASHER, SPRING 2-6	
40	021060106	4	1シユナツト6	NUT, 1 M6	
41	200190001	5	ステツプル	STAPLE	
42	S18633109	1	モ-タカバー	MOTOR COVER	
43	032422003	3	+マルモクネジ4.1X20	WOOD SCREW, ROUND M4.1X20	
44	116662003	3	ザガネ	WASHER	
45	S20137001	1	モ-ターウシロカバー	MOTOR BACK COVER	
46	138444001	2	ナベBタイト4X14	TAPTITE, CUP B M4X14	
47	025040232	2	ヒラザガネチユウ4	WASHER, PLAIN M 4	
48	144226001	1	トウフカバー	HEAD COVER	
49	146256001	4	クツシヨソカナダ	CUSHION COLLAR	
50	146255000	4	クツシヨソ	CUSHION	
51	S00617000	4	ボウシンゴムカラー	RUBBER COLLAR	
52	133740006	4	カクネボルト6X70	BOLT, M6X70	
53	021060106	4	1シユナツト6	NUT, 1 M6	
54	025060336	4	ヒラザガネダイ6	WASHER, PLAIN L 6	
55	032461606	2	+マルモクネジ4.5X16	WOOD SCREW, ROUND M4.5X16	
56	S38044001	1	ヒンジオサエ	HINGE PRESSER	
57	032422003	2	+マルモクネジ4.1X20	WOOD SCREW, ROUND M4.1X20	
58	S07783001	1	6カクボウスバナ1.5	HEXAGONAL WRENCH, 1.5	
73	S41331001	1	テンシヨソプ-リオオクミ	TENSION PULLEY ASSY WITH SCREW	
73-1	152852101	1	テンシヨソプ-リクミ	TENSION PULLEY ASSY	
73-1-1	048320242	1	トメワアナノウC32	RETAINING RING, C32	
73-1-2	141860001	1	シメネジ6.35	SCREW 6.35	
73-2	018081222	1	アナボルト8X12	BOLT, SOCKET M8X12	
73-3	025080232	1	ヒラザガネチユウ8	WASHER, PLAIN M8	
73-4	028080242	1	バネザガネ2-8	WASHER, SPRING 2-8	
<オプションパーツ/OPTION PARTS>					
15	S06706001	1	シリコソオイル	SILICONE OIL	
<B433EX>					
70	S41154000	1	PROMX33セイギヨクミ(データナシ)	PROM CONTROL X33 ASSY(NO DATA)	
70-1	S38143000	1	CMOSLSI27C512	CMOSLSI27C512	

From the library of: Diamond Needle Corp

仕様別部品一覧表/DIFFERENT PARTS LIST/ZUBEHÖRLISTE/
LISTE DES PIÈCES ACCESSOIRES/LISTA DE PIEZAS ACCESORIAS

★表中◎部品は、LK3-B430門止めミシンと共通です。○部品は、BAS-304Aプログラム式電子ミシンと共通です。
★In the following table, parts marked with ◎ are common with the LK3-B430; parts with ○ are common with the BAS-304A.

機種/Model	B430E			
サブクラス/Subclass	-2	-1	-5	-7
品名 用途 Use Part name	デニム用 For denim	被服用 For general clothing		メリヤス用 For knitted wear
針穴板 Needle hole plate	○針穴板E(φ2.6) S10212-101	○針穴板F(φ2.2) S10213-001		○針穴板A(φ1.6) S10211-001
中がま箱組 Shuttle hook box assy	◎中がまB箱組 152687-902	◎中がまA箱組 152685-902		
大がま Large shuttle hook	◎大がまB 152686-001	◎大がまA 152682-001		
主調子ばね Tension spring	◎主調子ばね 107606-001	◎主調子ばね 104525-001		
糸取りばね Spring	◎糸取りばねB 144588-001	◎糸取りばね 145519-001		
大がま体組 Shuttle race base assy	◎大がま体組 S02427-201		大がま体メリヤス組 S37976-001	
大がま体 Shuttle race base	◎大がま体 S02428-001		大がま体メリヤス S37977-001	
ミシン針組 Needle assy	ミシン針 DP17NY19組 S37928-419	ミシン針 DPX5(16)組 107415-416		ミシン針 DPX5(9)組 107415-409
針 Needle	DPX17NY#19 S37928-019	◎DPX5#16 107415-016		◎DPX5#9 107415-009
押さえ腕組 Presser arm assy	押さえ腕組デニム S37948-009	押さえ腕組 S37952-009	押さえ腕組メリヤス S37953-009	
押さえばね Spring	◎押さえばねC 154356-001	◎押さえばねA 153568-001		
押さえ足R Work clamp	◎5.6X23(3mm用) 153608-101	◎4X18(2mm用) 152777-001	◎4X12(2mm用) 152779-001	
押さえ足L Work clamp	◎5.6X23(3mm用) 154527-001	◎4X18(2mm用) 152778-001	◎4X12(2mm用) 152780-001	
送り板 Feed plate	◎ 153610-101	◎12X31(沈下式L) 153055-201	◎12X24(沈下式S) 153207-201	◎5X13(2mm用) 152791-201

機種/Model	B431E		B433E		
サブクラス/Subclass	-2	-3	—		
品名 用途 Use Part name	被服用 For general clothing		デニム用 For denim	被服用 For general clothing	メリヤス用 For knitted wear
針穴板 Needle hole plate	○針穴板F(φ2.2) S10213-001		○針穴板E(φ2.6) S10212-101	○針穴板F(φ2.2) S10213-001	○針穴板A(φ1.6) S10211-001
中がま箱組 Shuttle hook box assy	◎中がまA箱組 152685-902	◎中がまB箱組 152687-902	◎中がまA箱組 152685-902		
大がま Large shuttle hook	◎大がまA 152682-001	◎大がまB 152686-001	◎大がまA 152682-001		
主調子ばね Tension spring	◎主調子ばね 104525-001	◎主調子ばね 107606-001	◎主調子ばね 104525-001		
糸取りばね Spring	◎糸取りばね 145519-001	◎糸取りばねB 144588-001	◎糸取りばね 145519-001		
大がま体組 Shuttle race base assy	◎大がま体組 S02427-201			大がま体メリヤス組 S37976-001	
大がま体 Shuttle race base	◎大がま体 S02428-001			大がま体メリヤス S37977-001	
ミシン針組 Needle assy	ミシン針 DPX5(16)組 107415-416		ミシン針 DP17NY(19)組 S37928-419	ミシン針 DPX5(16)組 107415-416	ミシン針 DPX5(9)組 107415-409
針 Needle	◎DPX5#16 107415-016		DPX17NY#19 S37928-019	◎DPX5#16 107415-016	◎DPX5#9 107415-009
押さえ腕組 Presser arm assy	押さえ腕組 431-S S41227-009	押さえ腕組 431-L S41228-009	押さえ腕組B S40647-009	押さえ腕組A S40646-009	
押さえばね Spring	—	—	◎押さえばねB 153569-001	◎押さえばねA 153568-001	
押さえ足 Work clamp	押さえ足431-S S54416-001	押さえ足431-L S54417-001	—	—	
送り板 Feed plate	送り板S S54419-201	送り板L S54420-201	—		

★標準の押さえ足、送り板のサイズは、次のとおりです。(実際の縫製エリアは、外枠寸法から約1.5mm内側になります。)

★Standard sizes for work clamps and feed plates are as follows:

(The actual sewing area has 1.5mm margin on every size; inside the lines with the dimensions indicate.)

機種/Model	B430E				B431E	
仕様/Specification	-1	-5	-2	-7	-2	-3
◎押さえ足R	152777-001	152779-001	153608-101	152779-001	154416-001	154417-001
◎押さえ足L	152778-001	152780-001	154527-001	152780-001		
Work clamp R						
Work clamp L						
◎送り板	153055-201	153207-201	153610-101	152791-201	154419-201	054420-201
Feed plate						

ゲージ部品一覧表 / GAUGE PARTS LIST / LEHRENLISTE / LIST DES PIÈCES D'ECARTEMENT / LISTA DE PIEZAS CARIBRADORAS

押さえ足と送り板は、上下の組合せになります。/ Each work clamp pair is used in combination with the feed plate directly below them.

◎押さえ足R,L / Work clamps Rand L

152781-001(デニム)	153201-001(PL)	153203-001(PS)	S00906-001(1 Inch)	S33747-001(30mm)
152782-001(デニム)	153202-001(PL)	153204-001(PS)	S00907-001(1 Inch)	S33748-001(30mm)

◎送り板 / Feed plate

152792-001(デニム)	153205-201(PL)	153206-201(PS)	S00908-001(1 Inch)	S33749-001(30mm)

◎針穴板 / Needle hole plate

A S10211-001	D S29997-001	E S10212-101	F S10213-001	H S30450-001
L S25127-001	M S34348-001	ED S30925-001	FD S30926-001	BZ S41013-001

警告ラベル / Warning labels / Warnschilder / Etiquettes d'avertissement / Etiquetas de advertencia

	品名 / Name of parts	Size(mm)	Code
	操作注意ラベル・和	40×64	S38350-001
	Label, operation Eng.	40×64	S38349-001
	電撃ラベル・和	40×64	S38353-001
	Label, elec. shock 4 lang.	35×118	S38352-001
	PEマーク Mark, PE	7.5×12.5	S37059-001